

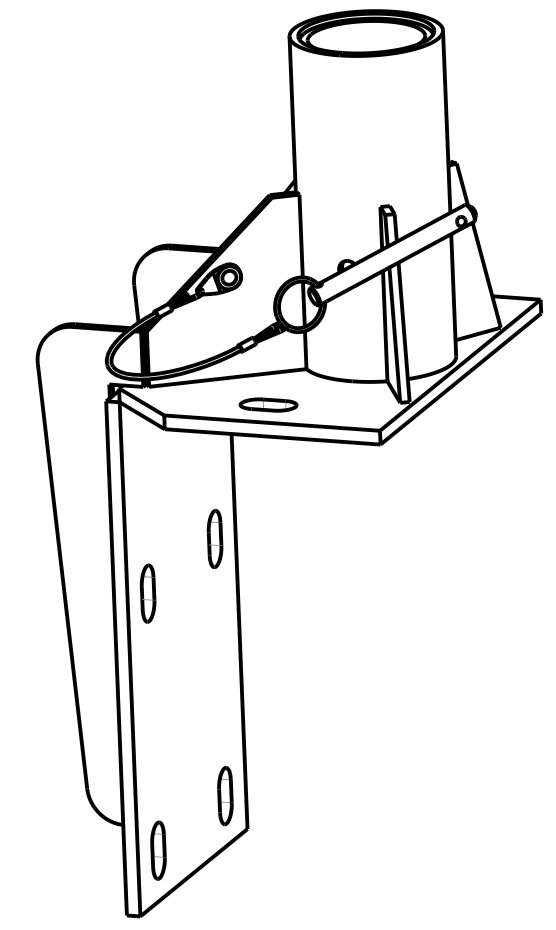

Product number: IN-2117

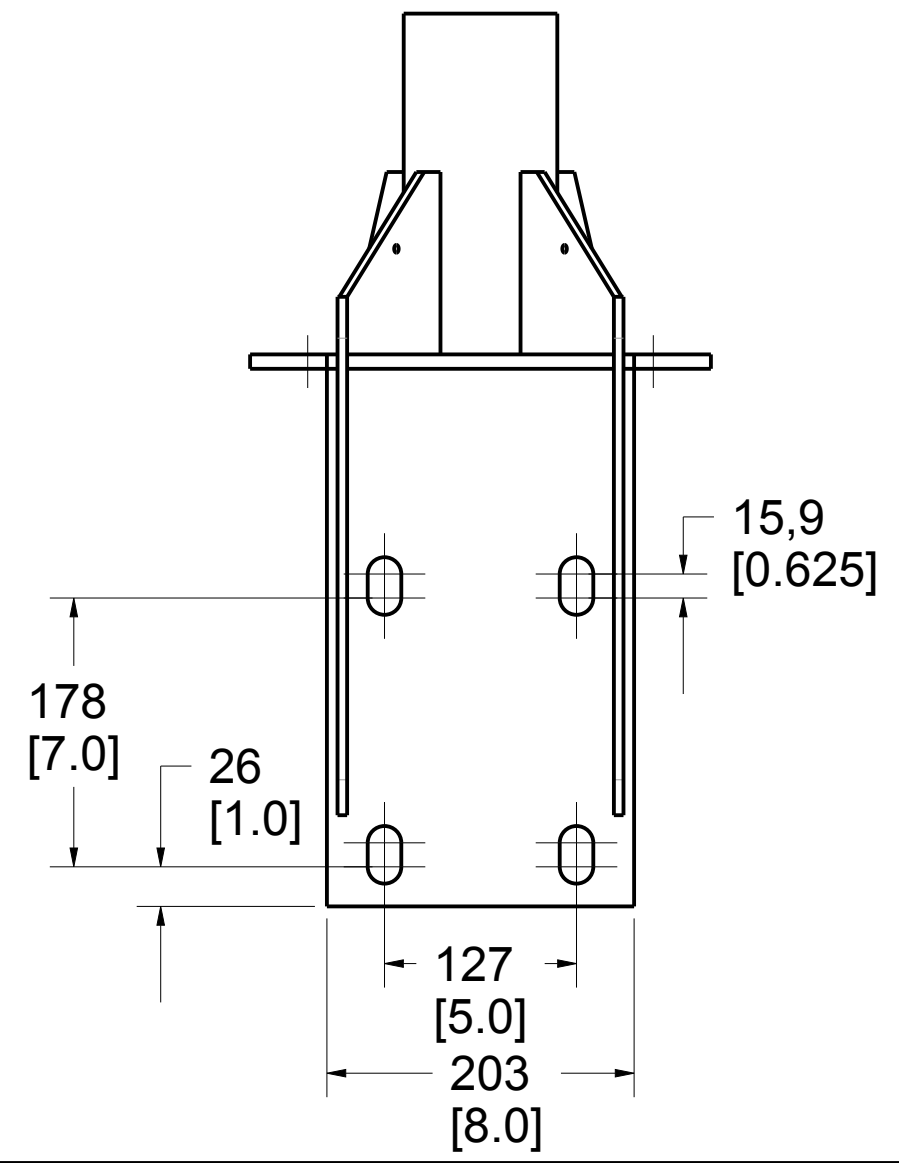
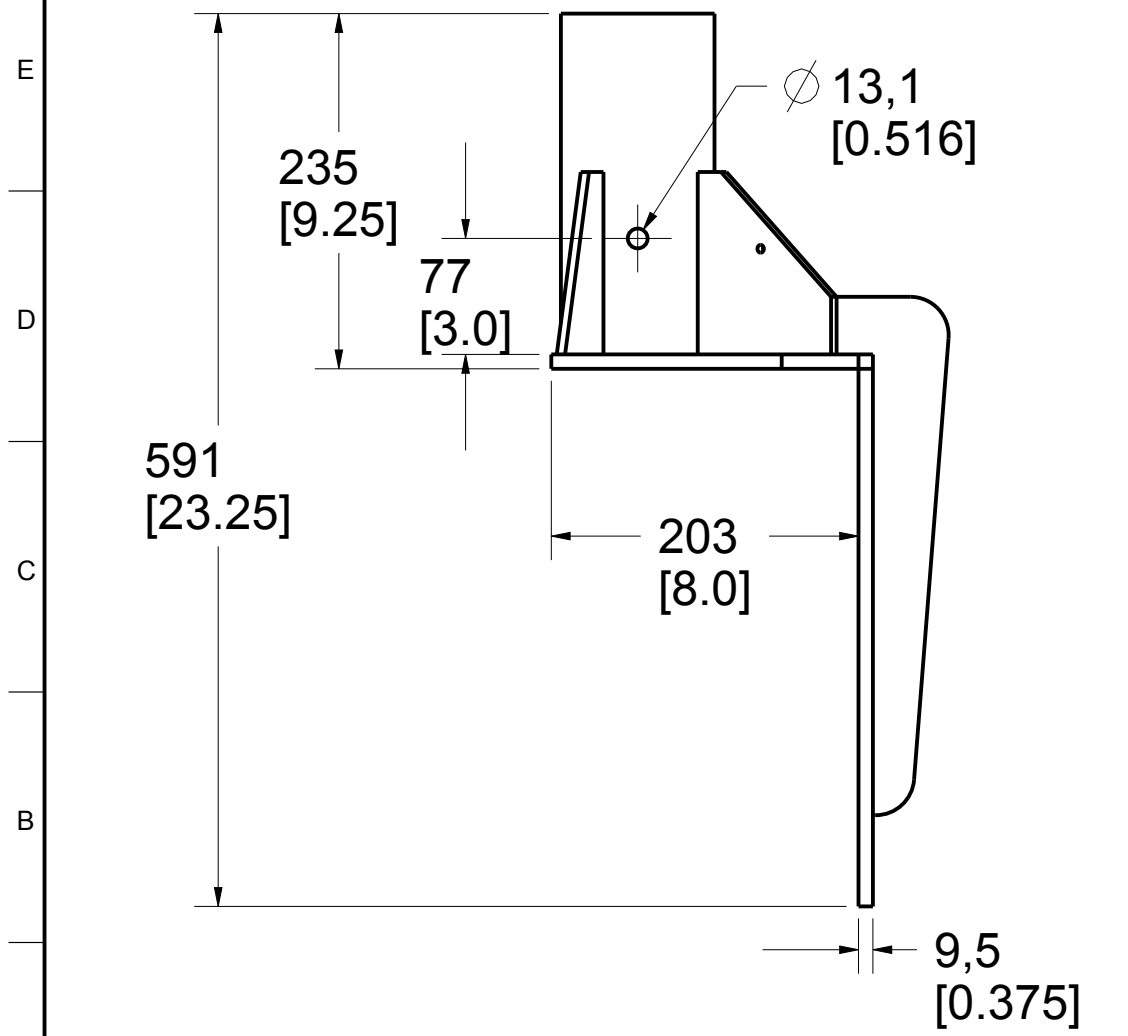
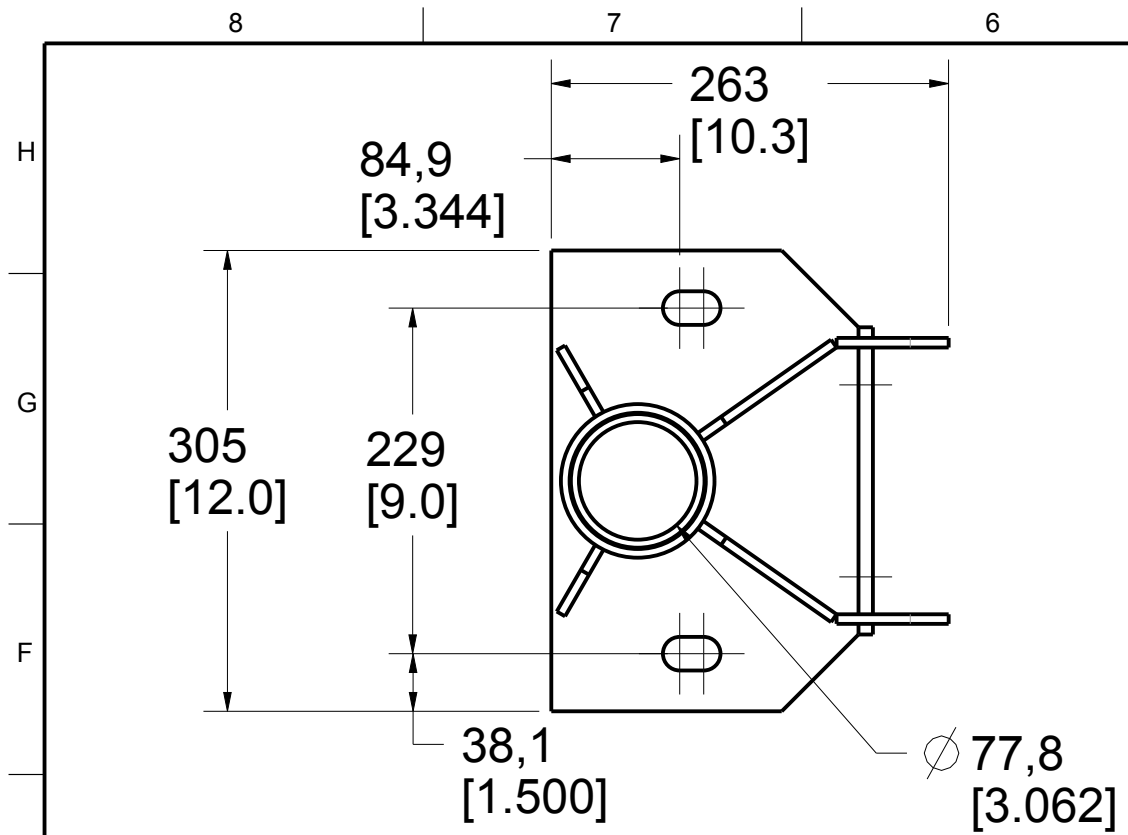

PAT.NO.:				
PRODUITS DE SERVICE PUBLICS INNOVA INC. INNOVA PUBLIC UTILITY PRODUCTS INC.				
© 9105-0732 QUEBEC INC. and under exclusive license to INNOVA PUBLIC UTILITY PRODUCTS INC., (hereafter « INNOVA »). All rights reserved. Protected under the Copyright Act of Canada and international treaties and agreements regarding copyrights. Violators are subject to prosecution and other legal recourses for infringement. Any reproduction, adaptation or other use or disclosure whatsoever, in totality or in part, and in any form or by any means whatsoever, strictly forbidden and requires the prior written approval of INNOVA. All data is the exclusive property of 9105-0732 QUEBEC INC. and under exclusive license to INNOVA and cannot be used nor disclosed in any way either without the prior written approval of INNOVA.				
WEIGHT:	TITLE:			
35.3 Lb	76mm (3") Top Wall Adapter 90 degree			
16.0 Kg				
COLOR:	Material:	SHEET(S):	PROJET:	Rev.
	SS 304	1 / 5	IN-2117	04

Base Installation Requirements

Product number: **IN-2117**

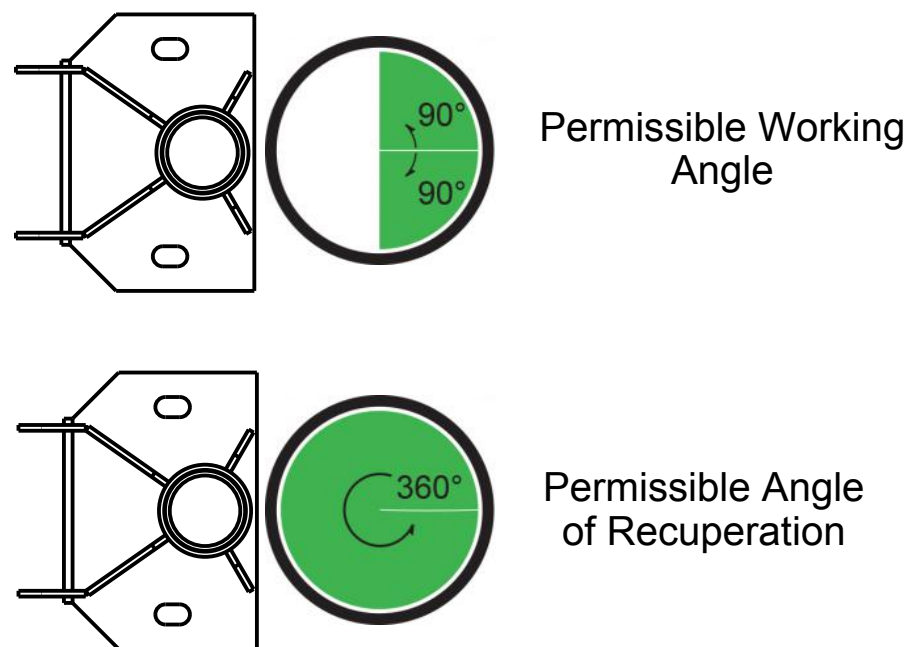
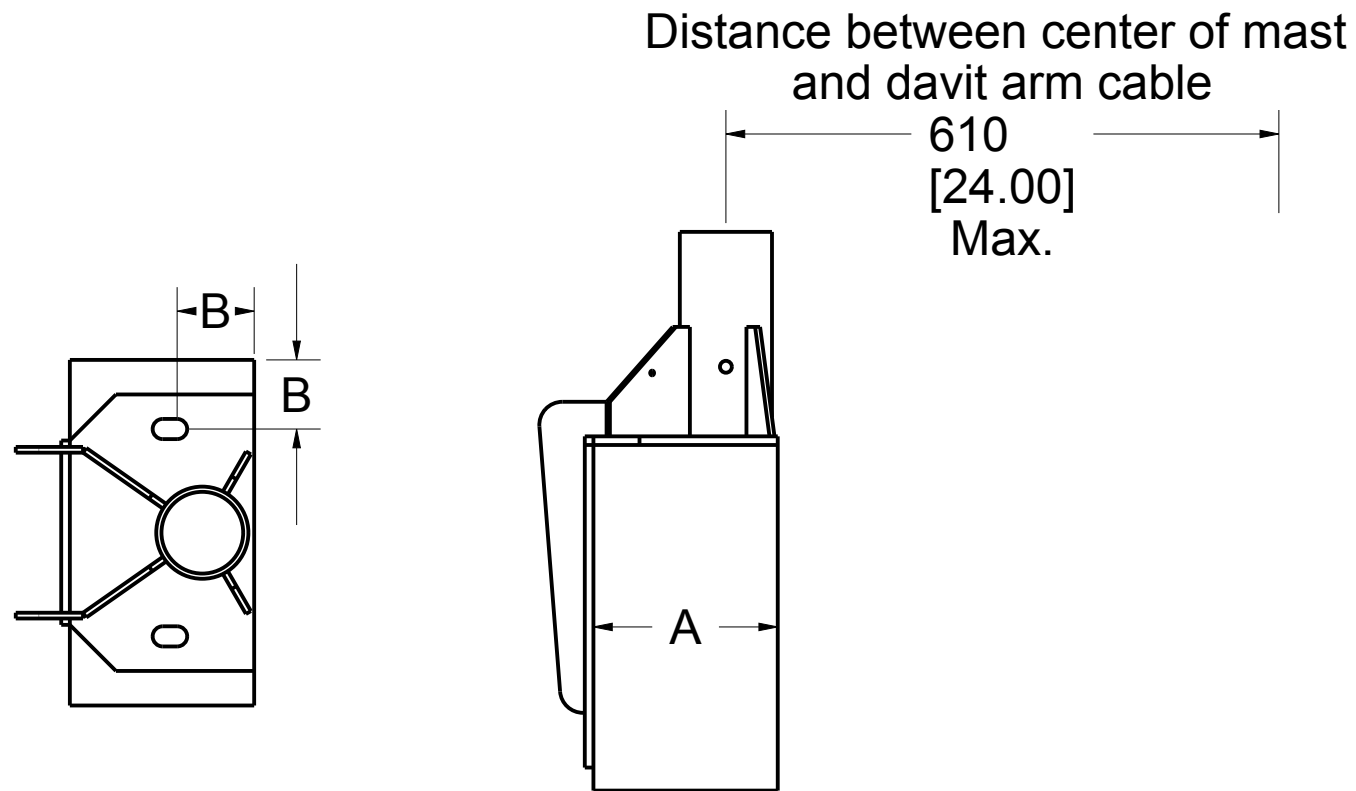

ANSI, CSA, OSHA

	Full thickness	Example *	Sandwich	Example *
Minimum thickness (A)	Refer to fastener manufacturer specifications	203 mm (8.00")	N / A	N / A
Minimum edge distance (B)	Refer to fastener manufacturer specifications	152 mm (6.00")	N / A	N / A
Embedment depth	Refer to fastener manufacturer specifications	152 mm (6.00")	N / A	N / A
Minimum pullout strength per fastener	15,9 kN (3 574 lbf)	15,9 kN (3 574 lbf)	N / A	N / A
Maximum moment applied to the structure	9,8 kN•m (86 400 lbf•in)	9,8 kN•m (86 400 lbf•in)	N / A	N / A
Maximum vertical load applied to the structure	22,3 kN (5 000 lbf)	22,3 kN (5 000 lbf)	N / A	N / A

Note:

1. It is the responsibility of the local engineer to assure installation compliance.
2. To be installed with 3/4" (M20) minimum ϕ stainless steel anchors. Smaller anchors must be validated by the local engineer.
3. All other variation must be approved by the local engineer.
4. *Typical installation concrete for 21 MPa (3000 psi) and 0.2% gross area rebar reinforcement.
5. Tolerance of flatness around adapter contour and wall shall not exceed 3/8" (9,5mm).

PAT.NO.:



PRODUITS DE SERVICE PUBLICS INNOVA INC.
INNOVA PUBLIC UTILITY PRODUCTS INC.

© 9105-0732 QUEBEC INC. and under exclusive license to INNOVA PUBLIC UTILITY PRODUCTS INC., (hereafter « INNOVA »). All rights reserved. Protected under the Copyright Act of Canada and international treaties and agreements regarding copyrights. Violators are subject to prosecution and other legal recourses for infringement. Any reproduction, adaptation or other use or disclosure whatsoever, in totality or in part, and in any form or by any means whatsoever, strictly forbidden and requires the prior written approval of INNOVA. All data is the exclusive property of 9105-0732 QUEBEC INC. and under exclusive license to INNOVA and cannot be used nor disclosed in any way either without the prior written approval of INNOVA.

WEIGHT:

TITLE:

35.3 Lb

76mm (3") Top Wall Adapter 90 degree

16.0 Kg

COLOR:

Material:

SS 304

SHEET(S):

2 / 5

PROJET:

IN-2117

Rev.

04

Base Installation Requirements

Product number: **IN-2117**

Distance between center of mast
and davit arm cable

610
[24.00]
Max.

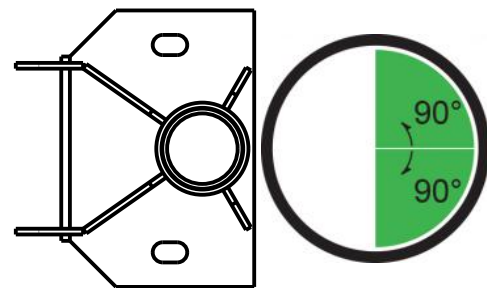
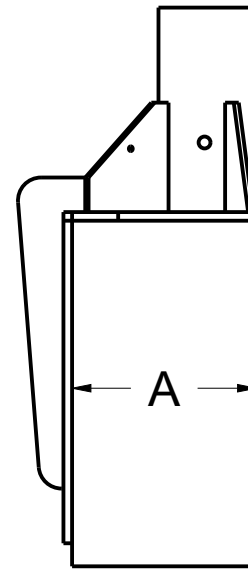
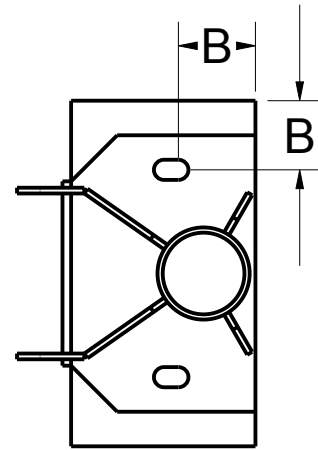

Permissible Working
Angle

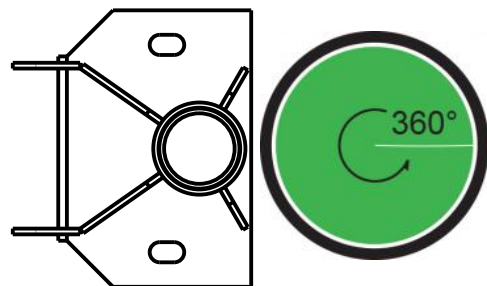

Permissible Angle
of Recuperation

EN 795, TS16415

	Full thickness	Sandwich
Minimum thickness (A)	Refer to fastener manufacturer specifications	N / A
Minimum edge distance (B)	Refer to fastener manufacturer specifications	N / A
Embedment depth	Refer to fastener manufacturer specifications	N / A
Minimum pullout strength per fastener	12,9 kN (2 900 lbf)	N / A
Maximum moment applied to the structure	7,9 kN•m (69 921 lbf•in)	N / A
Maximum vertical load applied to the structure	13,0 kN (2 923 lbf)	N / A

Note:

1. It is the responsibility of the local engineer to assure installation compliance.
2. To be installed with 3/4" (M20) minimum \varnothing stainless steel anchors. Smaller anchors must be validated by the local engineer.
3. All other variation must be approved by the local engineer.
4. Tolerance of flatness around adapter contour and wall shall not exceed 3/8" (9,5mm).

PAT.NO.:



PRODUITS DE SERVICE PUBLICS INNOVA INC.
INNOVA PUBLIC UTILITY PRODUCTS INC.

© 9105-0732 QUEBEC INC. and under exclusive license to INNOVA PUBLIC UTILITY PRODUCTS INC., (hereafter « INNOVA »). All rights reserved. Protected under the Copyright Act of Canada and international treaties and agreements regarding copyrights. Violators are subject to prosecution and other legal recourses for infringement. Any reproduction, adaptation or other use or disclosure whatsoever, in totality or in part, and in any form or by any means whatsoever, strictly forbidden and requires the prior written approval of INNOVA. All data is the exclusive property of 9105-0732 QUEBEC INC. and under exclusive license to INNOVA and cannot be used nor disclosed in any way either without the prior written approval of INNOVA.

WEIGHT:

TITLE:

35.3 Lb

76mm (3") Top Wall Adapter 90 degree

16.0 Kg

COLOR:

Material:

SS 304

SHEET(S):

3 / 5

PROJET:

IN-2117

Rev.

04

SPECIFICATIONS

This equipment is considered as part of a personal fall arrest system (PFAS).
 It is only to be used in conjunction with a personal fall arrest system that limits the maximum arrest force (MAF) to 6,0 kN.

Working load limit (WLL) :	164 kg	(360 lb)
Minimum breaking strength :	16,0 kN	(3 600 lbf)
Maximum working moment :	0,976 kN•m	(8 640 lbf•in)
Maximum design moment :	9,8 kN•m	(86 400 lbf•in)

STANDARDS

Name	Classification	Year	Users
ANSI Z359.1		2007	1
CSA Z259.2.1		1998	1
OSHA 1910.66 AppC			1
EN 795		2012	1
TS 16415		2013	2

MATERIAL AND CONSTRUCTION

Structure : Stainless Steel 304
 Hardware : Stainless Steel
 Welding certification : Steel / Stainless Steel : CSA W59.18 / CSA W47.1 and AWS D1.6

RESTRICTIONS

This equipment is to be used only with products approved by Innova Public Utility Products Inc.
 This equipment must always be operated on a level surface.
 Ensure that all hardwares and connecting pins are properly installed before use.
 In the occurrence of a fall or that the safety of the equipment is in doubt, the equipment must be immediately removed from service and inspected by qualified personnel before reuse.

Product number: **IN-2117**

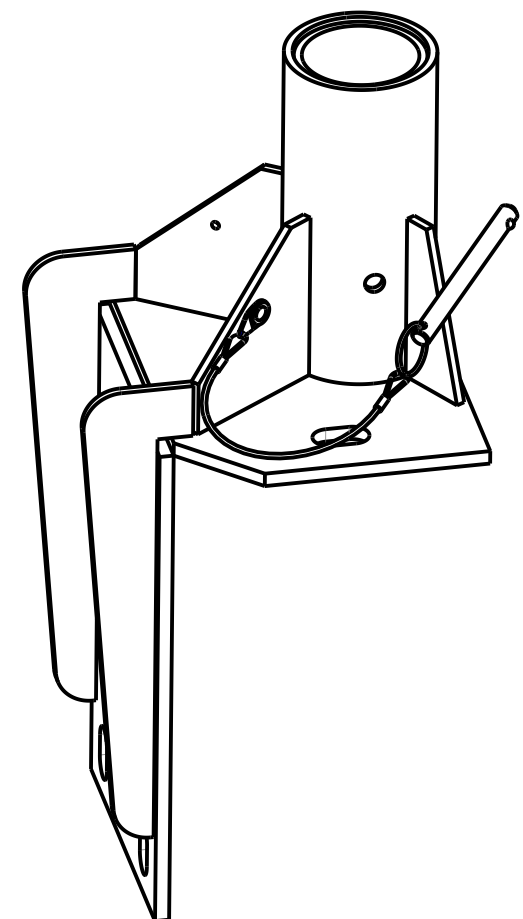

PAT.NO.:				
PRODUITS DE SERVICE PUBLICS INNOVA INC. INNOVA PUBLIC UTILITY PRODUCTS INC.				
© 9105-0732 QUEBEC INC. and under exclusive license to INNOVA PUBLIC UTILITY PRODUCTS INC., (hereafter « INNOVA »). All rights reserved. Protected under the Copyright Act of Canada and international treaties and agreements regarding copyrights. Violators are subject to prosecution and other legal recourses for infringement. Any reproduction, adaptation or other use or disclosure whatsoever, in totality or in part, and in any form or by any means whatsoever, strictly forbidden and requires the prior written approval of INNOVA. All data is the exclusive property of 9105-0732 QUEBEC INC. and under exclusive license to INNOVA and cannot be used nor disclosed in any way either without the prior written approval of INNOVA.				
WEIGHT:	TITLE:			
35.3 Lb	76mm (3") Top Wall Adapter 90 degree			
16.0 Kg				
COLOR:	Material:	SHEET(S):	PROJET:	Rev.
	SS 304	4 / 5	IN-2117	04

8

7

6

5

4

3

2

1

Product number: IN-2117

H
G
F
E
D
C
B
A

H
G
F
E
D
C
B
A

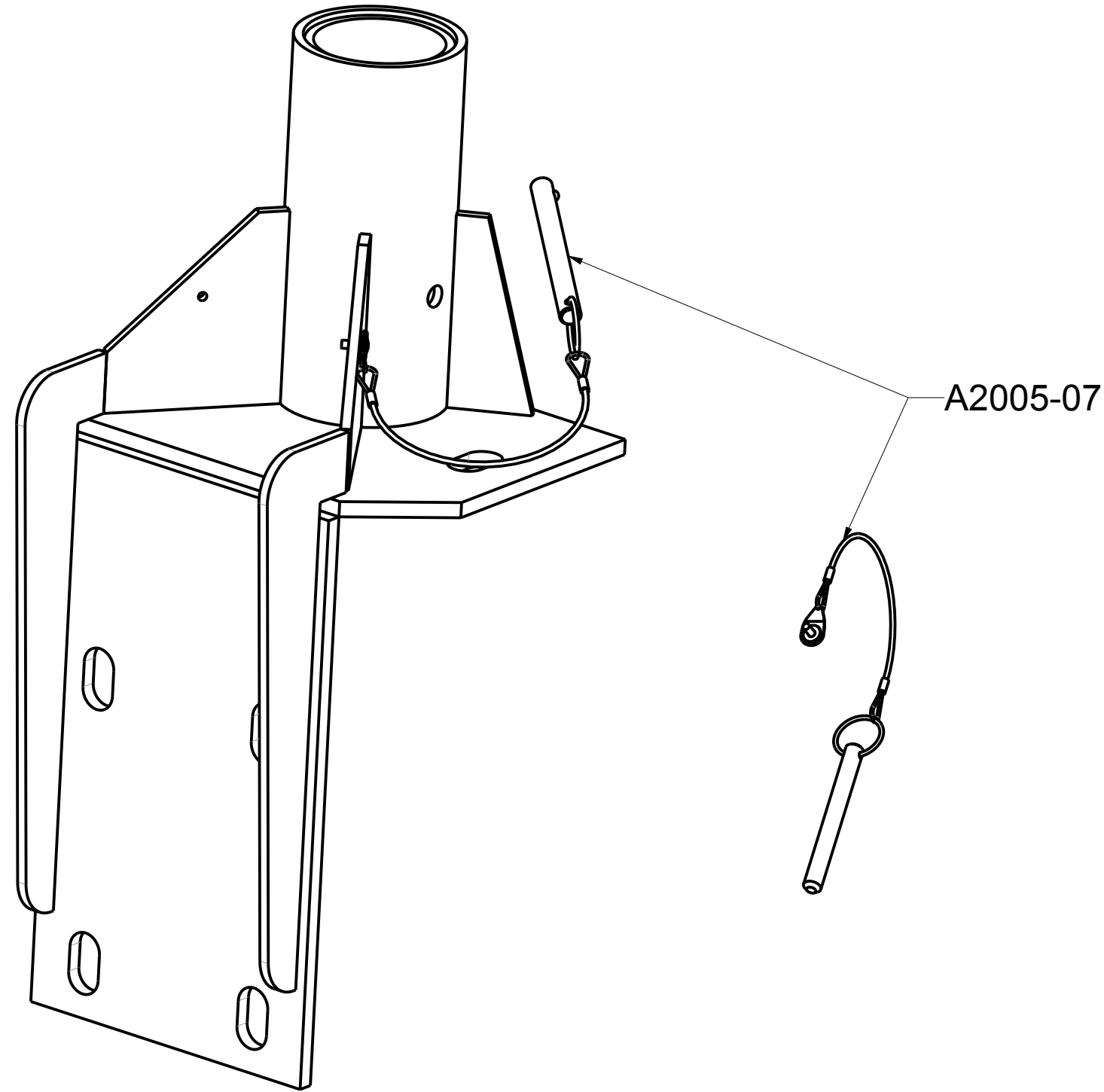

PAT.NO.:	

PRODUITS DE SERVICE PUBLICS INNOVA INC.
INNOVA PUBLIC UTILITY PRODUCTS INC.

© 9105-0732 QUEBEC INC. and under exclusive license to INNOVA PUBLIC UTILITY PRODUCTS INC., (hereafter « INNOVA »). All rights reserved. Protected under the Copyright Act of Canada and international treaties and agreements regarding copyrights. Violators are subject to prosecution and other legal recourses for infringement. Any reproduction, adaptation or other use or disclosure whatsoever, in totality or in part, and in any form or by any means whatsoever, strictly forbidden and requires the prior written approval of INNOVA. All data is the exclusive property of 9105-0732 QUEBEC INC. and under exclusive license to INNOVA and cannot be used nor disclosed in any way either without the prior written approval of INNOVA».

WEIGHT:	TITLE:			
35.3 Lb	76mm (3") Top Wall Adapter 90 degree			
16.0 Kg				

COLOR:	Material:	SHEET(S):	PROJET:	Rev.
	SS 304	5 / 5	IN-2117	04

8

7

6

5

4

3

2

1