

PAT.NO.:				
PRODUITS DE SERVICE PUBLICS INNOVA INC. INNOVA PUBLIC UTILITY PRODUCTS INC.				
<small>© 9105-0732 QUEBEC INC. and under exclusive license to INNOVA PUBLIC UTILITY PRODUCTS INC., (hereafter « INNOVA »). All rights reserved. Protected under the Copyright Act of Canada and international treaties and agreements regarding copyrights. Violators are subject to prosecution and other legal recourses for infringement. Any reproduction, adaptation or other use or disclosure whatsoever, in totality or in part, and in any form or by any means whatsoever, strictly forbidden and requires the prior written approval of INNOVA. All data is the exclusive property of 9105-0732 QUEBEC INC. and under exclusive license to INNOVA and cannot be used nor disclosed in any way either without the prior written approval of INNOVA.</small>				
WEIGHT:	TITLE:			
115.0 Lb	76mm (3") Adjustable Wall Adapter			
52.2 Kg	610mm-1143mm (24"-45")			
COLOR:	Material:	SHEET(S):	PROJET:	Rev.
Yellow XTIRPA	Aluminum	1 / 5	IN-2125	02

Product number: **IN-2125**

Recommendations:

Concrete must be made of 0,2% gross area rebar reinforced 21 MPa (3 000 psi) or better
Minimum thickness of 191 mm (7-1/2")
or
Non reinforced Concrete
21 MPa (3 000 psi) or better.
Minimum thickness of 286 mm (11 1/4")

Moment load : 9,8 kN•m (86 400 lbf•in)
Verticale load : 22,241 N (5 000 lbf)

N.B. It is the responsibility of the field engineer to assure installation compliance.

min.
1727 [68.0]
max.
2159 [85.0]

IN-2210

min.
381 [15.0]
max.
610 [24.0]

IN-2003

191 [7.5]
Minimum

267 [10.5]
Minimum

Wall

610 [24.0] min.
1143 [45.0] max.

Torque Value (8x)
34-41 N•m (25-30 lbf•ft)

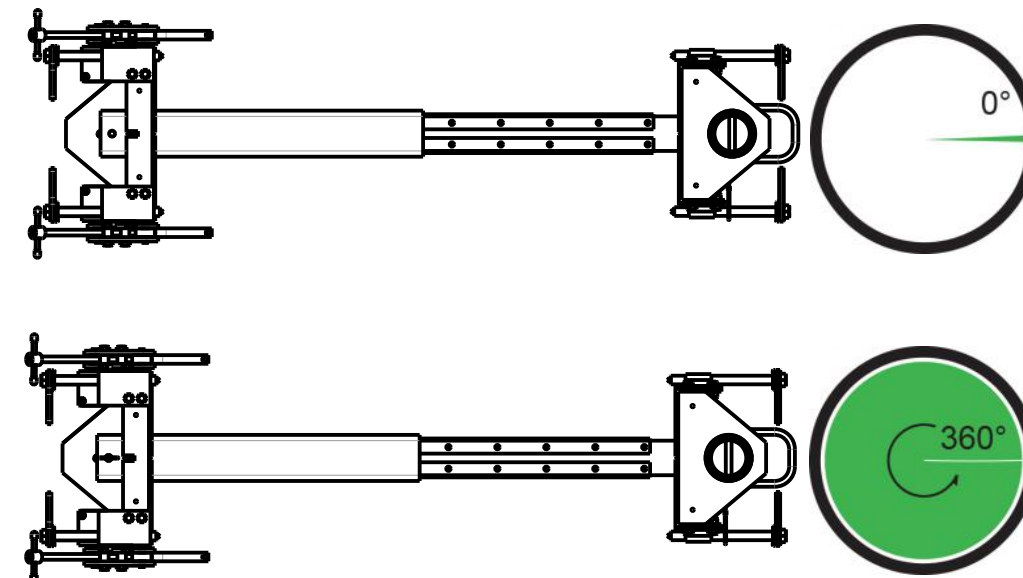

0°
Permissible Working Angle

360°
Permissible Angle of Recuperation

Adjustable positions:

Bottom position: 406 (16.0") to 483 (19.0")
Center position: 286 (11.25") to 362 (14.25")
Top position: 191 (7.5") to 241 (9.5")

PAT.NO.:



PRODUITS DE SERVICE PUBLICS INNOVA INC.
INNOVA PUBLIC UTILITY PRODUCTS INC.

© 9105-0732 QUEBEC INC. and under exclusive license to INNOVA PUBLIC UTILITY PRODUCTS INC. (hereafter « INNOVA »). All rights reserved. Protected under the Copyright Act of Canada and international treaties and agreements regarding copyrights. Violators are subject to prosecution and other legal recourses for infringement. Any reproduction, adaptation or other use or disclosure whatsoever, in totality or in part, and in any form or by any means whatsoever, strictly forbidden and requires the prior written approval of INNOVA. All data is the exclusive property of 9105-0732 QUEBEC INC. and under exclusive license to INNOVA and cannot be used nor disclosed in any way either without the prior written approval of INNOVA.

WEIGHT:

TITLE:

115.0 Lb

76mm (3") Adjustable Wall Adapter

52.2 Kg

610mm-1143mm (24"-45")

COLOR:

Material:

SHEET(S):

PROJET:

Rev.

Yellow XTIRPA

Aluminum

2 / 5

IN-2125

02

SPECIFICATIONS

H This equipment is considered as part of a personal fall arrest system (PFAS).
 It is only to be used in conjunction with a personal fall arrest system that limits the maximum arrest force (MAF) to 6,0 kN.

G Working load limit (WLL) :	164 kg	(360 lb)
Minimum breaking strength :	16,0 kN	(3 600 lbf)
Maximum working moment :	1,0 kN•m	(8 640 lbf•in)
Maximum design moment :	9,8 kN•m	(86 400 lbf•in)

STANDARDS

F Name	Classification	Year	Users
ANSI Z359.1 (R1999)		2007	1
CSA Z259.2.1-1998		2011	1
OSHA 1910.66	App. C		1
E EN 795	B	2012	1
TS 16415		2013	2

MATERIAL AND CONSTRUCTION

D Structure:	Aluminum
Welding certification:	CSA W47.2M CSA W59 & 47.1
Surface finish:	Yellow Xtirpa

RESTRICTIONS

C This product is to be used only with products approved by Innova Public Utility Products inc.

IMPORTANT :

B All adjustment pins shall be used at all times.
 Always use the product perpendicular to the wall. It is not considered as a permanent structure.

**The positioning pins must always be in place when manoeuvring personnel. Otherwise, serious injuries may occur. Periodic inspections of hardware must be done. In the occurrence of a fall or the safety of the equipment is in doubt, equipment must be immediately removed from service and inspected by qualified personnel before reuse.

A ** This equipment must always be operated in a level position.

Product number: **IN-2125**

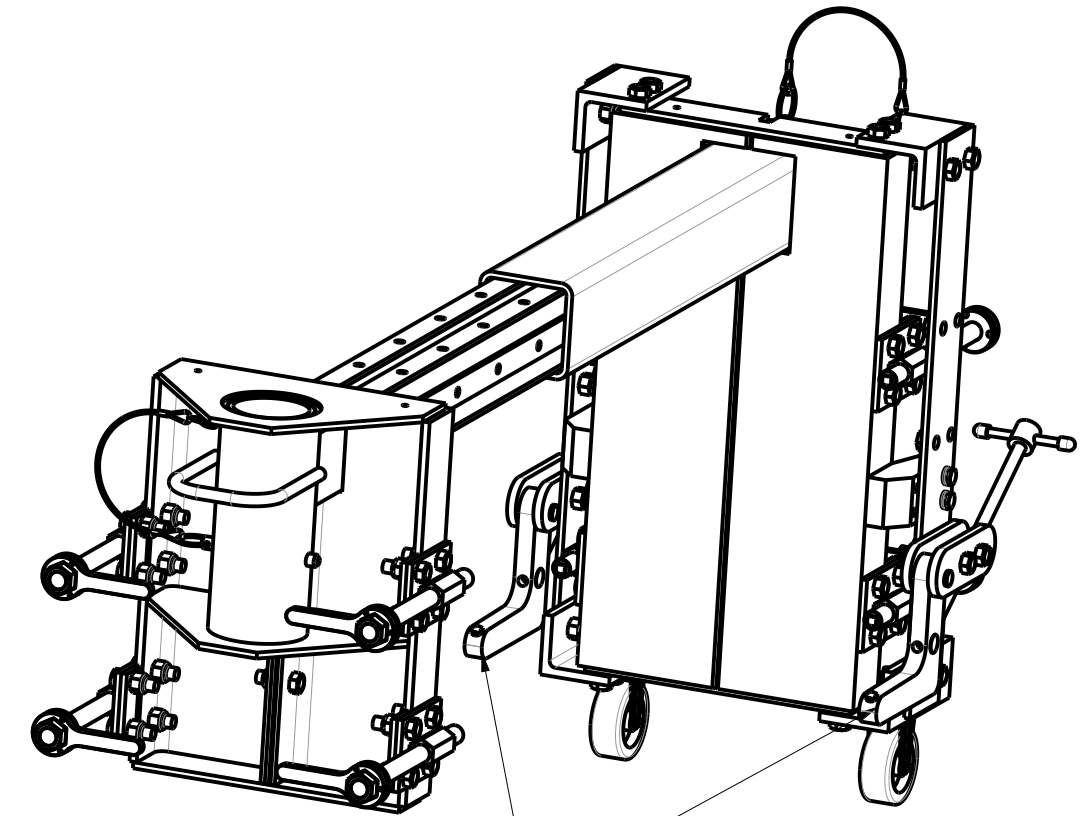

Stability Levers (2x)

Also Available Clear Anodized

PAT.NO.:				
PRODUITS DE SERVICE PUBLICS INNOVA INC. INNOVA PUBLIC UTILITY PRODUCTS INC.				
<small>© 9105-0732 QUEBEC INC. and under exclusive license to INNOVA PUBLIC UTILITY PRODUCTS INC., (hereafter « INNOVA »). All rights reserved. Protected under the Copyright Act of Canada and international treaties and agreements regarding copyrights. Violators are subject to prosecution and other legal recourses for infringement. Any reproduction, adaptation or other use or disclosure whatsoever, in totality or in part, and in any form or by any means whatsoever, strictly forbidden and requires the prior written approval of INNOVA. All data is the exclusive property of 9105-0732 QUEBEC INC. and under exclusive license to INNOVA and cannot be used nor disclosed in any way either without the prior written approval of INNOVA».</small>				
WEIGHT:	TITLE:			
115.0 Lb	76mm (3") Adjustable Wall Adapter			
52.2 Kg	610mm-1143mm (24"-45")			
COLOR:	Material:	SHEET(S):	PROJET:	Rev.
Yellow XTIRPA	Aluminum	3 / 5	IN-2125	02

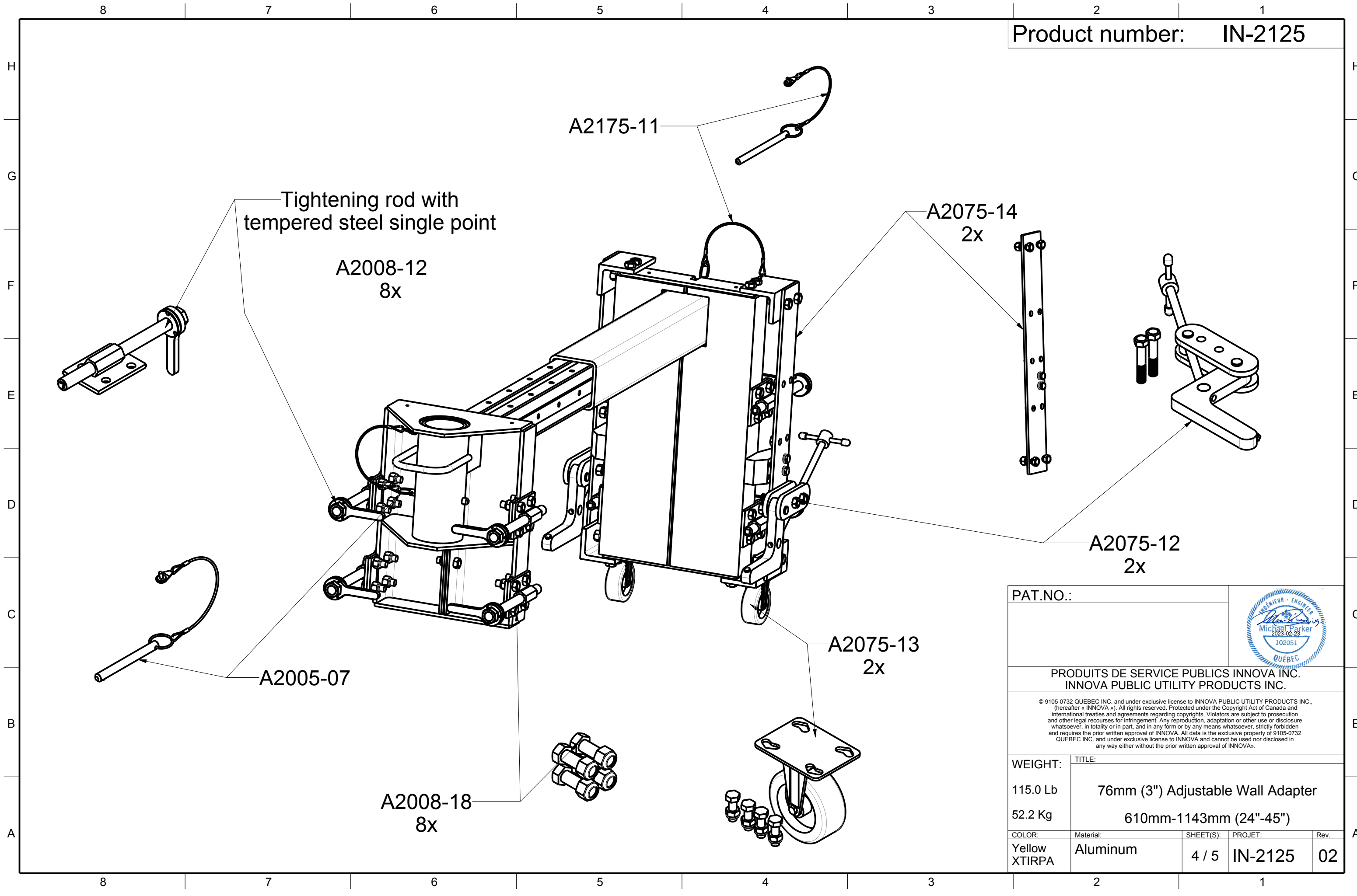

PAT.NO.:				
PRODUITS DE SERVICE PUBLICS INNOVA INC. INNOVA PUBLIC UTILITY PRODUCTS INC.				
<small>© 9105-0732 QUEBEC INC. and under exclusive license to INNOVA PUBLIC UTILITY PRODUCTS INC., (hereafter « INNOVA »). All rights reserved. Protected under the Copyright Act of Canada and international treaties and agreements regarding copyrights. Violators are subject to prosecution and other legal recourses for infringement. Any reproduction, adaptation or other use or disclosure whatsoever, in totality or in part, and in any form or by any means whatsoever, strictly forbidden and requires the prior written approval of INNOVA. All data is the exclusive property of 9105-0732 QUEBEC INC. and under exclusive license to INNOVA and cannot be used nor disclosed in any way either without the prior written approval of INNOVA.</small>				
WEIGHT:	TITLE:			
115.0 Lb	76mm (3") Adjustable Wall Adapter			
52.2 Kg	610mm-1143mm (24"-45")			
COLOR:	Material:	SHEET(S):	PROJET:	Rev.
Yellow XTIRPA	Aluminum	4 / 5	IN-2125	02

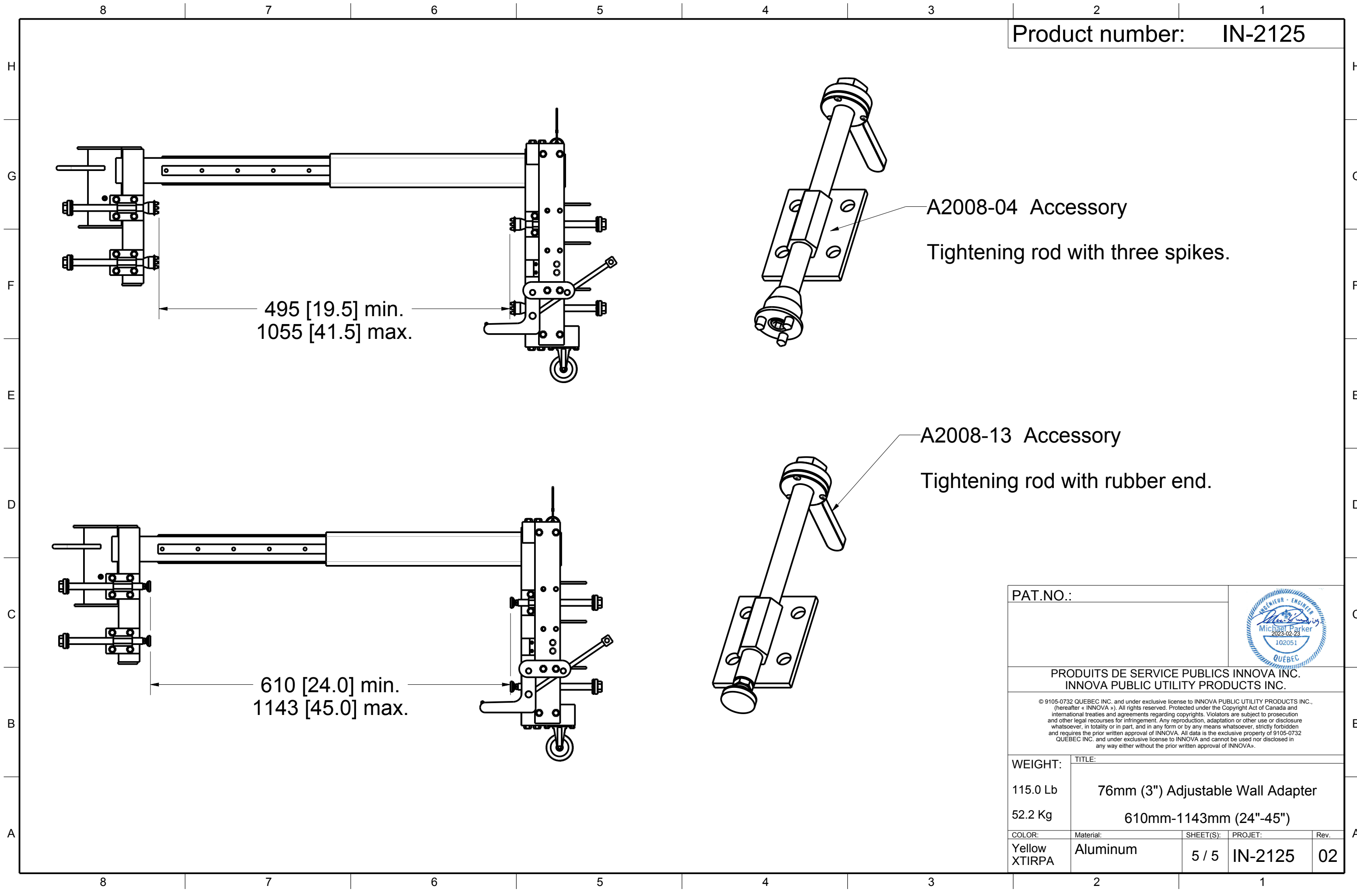

495 [19.5] min.
1055 [41.5] max.

A2008-04 Accessory
Tightening rod with three spikes.

610 [24.0] min.
1143 [45.0] max.

A2008-13 Accessory
Tightening rod with rubber end.

PAT.NO.:				
PRODUITS DE SERVICE PUBLICS INNOVA INC. INNOVA PUBLIC UTILITY PRODUCTS INC.				
<small>© 9105-0732 QUEBEC INC. and under exclusive license to INNOVA PUBLIC UTILITY PRODUCTS INC., (hereafter « INNOVA »). All rights reserved. Protected under the Copyright Act of Canada and international treaties and agreements regarding copyrights. Violators are subject to prosecution and other legal recourses for infringement. Any reproduction, adaptation or other use or disclosure whatsoever, in totality or in part, and in any form or by any means whatsoever, strictly forbidden and requires the prior written approval of INNOVA. All data is the exclusive property of 9105-0732 QUEBEC INC. and under exclusive license to INNOVA and cannot be used nor disclosed in any way either without the prior written approval of INNOVA.</small>				
WEIGHT:	TITLE:			
115.0 Lb	76mm (3") Adjustable Wall Adapter			
52.2 Kg	610mm-1143mm (24"-45")			
COLOR:	Material:	SHEET(S):	PROJET:	Rev.
Yellow XTIRPA	Aluminum	5 / 5	IN-2125	02