

Product number: A2126-09

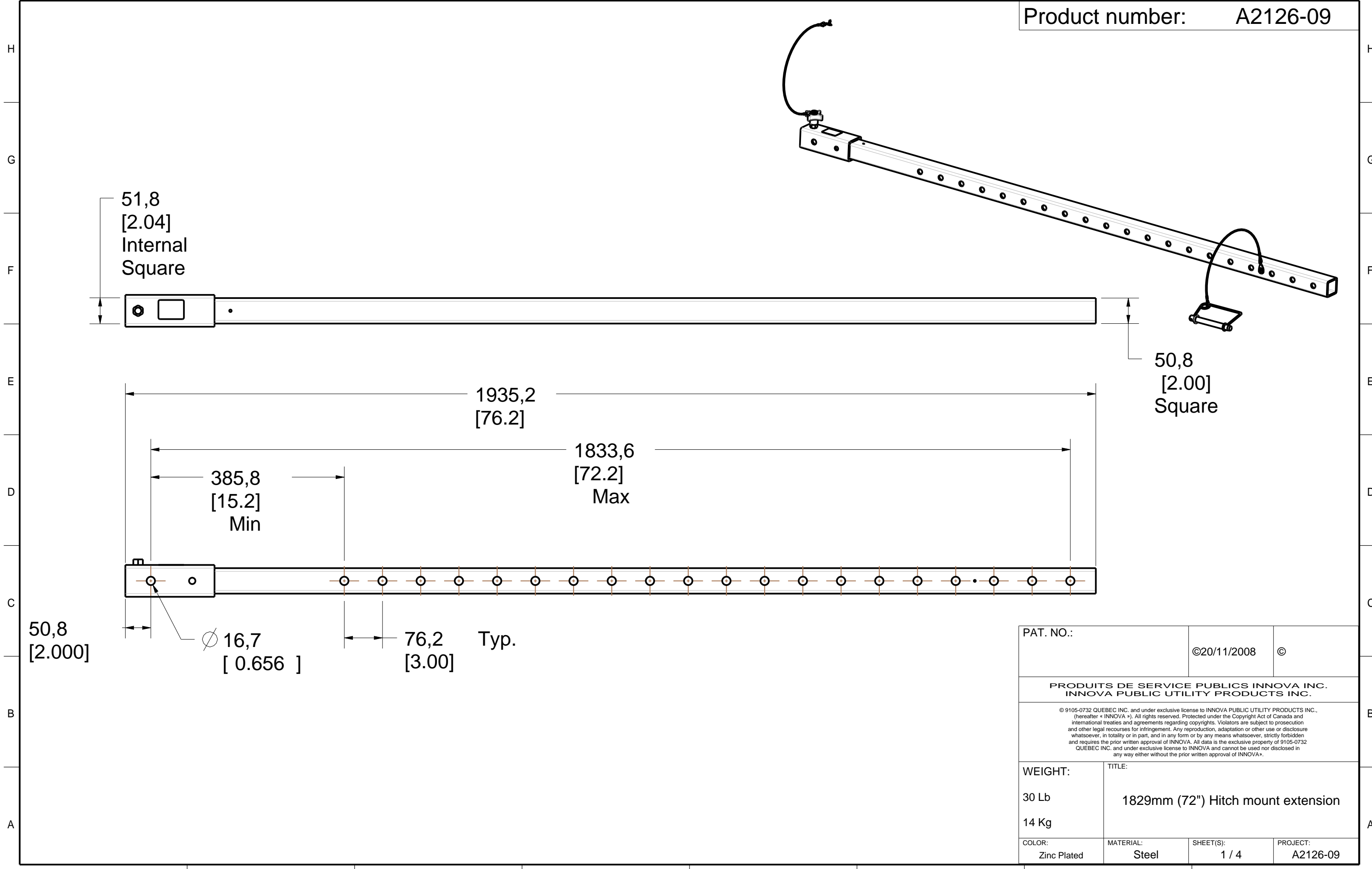

PAT. NO.:		©20/11/2008	©
PRODUITS DE SERVICE PUBLICS INNOVA INC. INNOVA PUBLIC UTILITY PRODUCTS INC.			
<small>© 9105-0732 QUEBEC INC. and under exclusive license to INNOVA PUBLIC UTILITY PRODUCTS INC., (hereafter « INNOVA »). All rights reserved. Protected under the Copyright Act of Canada and international treaties and agreements regarding copyrights. Violators are subject to prosecution and other legal recourses for infringement. Any reproduction, adaptation or other use or disclosure whatsoever, in totality or in part, and in any form or by any means whatsoever, strictly forbidden and requires the prior written approval of INNOVA. All data is the exclusive property of 9105-0732 QUEBEC INC. and under exclusive license to INNOVA and cannot be used nor disclosed in any way either without the prior written approval of INNOVA.</small>			
WEIGHT:	TITLE:		
30 Lb	1829mm (72") Hitch mount extension		
14 Kg			
COLOR:	MATERIAL:	SHEET(S):	PROJECT:
Zinc Plated	Steel	1 / 4	A2126-09

Hitch mount extension capacity per position

Position	Load Req (lb)	Load Req (Kg)
1	1804	820
2	1710	777
3	1625	739
4	1548	704
5	1478	672
6	1414	643
7	1355	616
8	1301	591
9	1251	569
10	1205	548
11	1162	528
12	1122	510
13	1085	493
14	1050	477
15	1018	463
16	987	449
17	958	435
18	931	423
19	905	411
20	880	400

NOTE:
When attached to a vehicle, the load on the axle must meet or exceed these required loads.

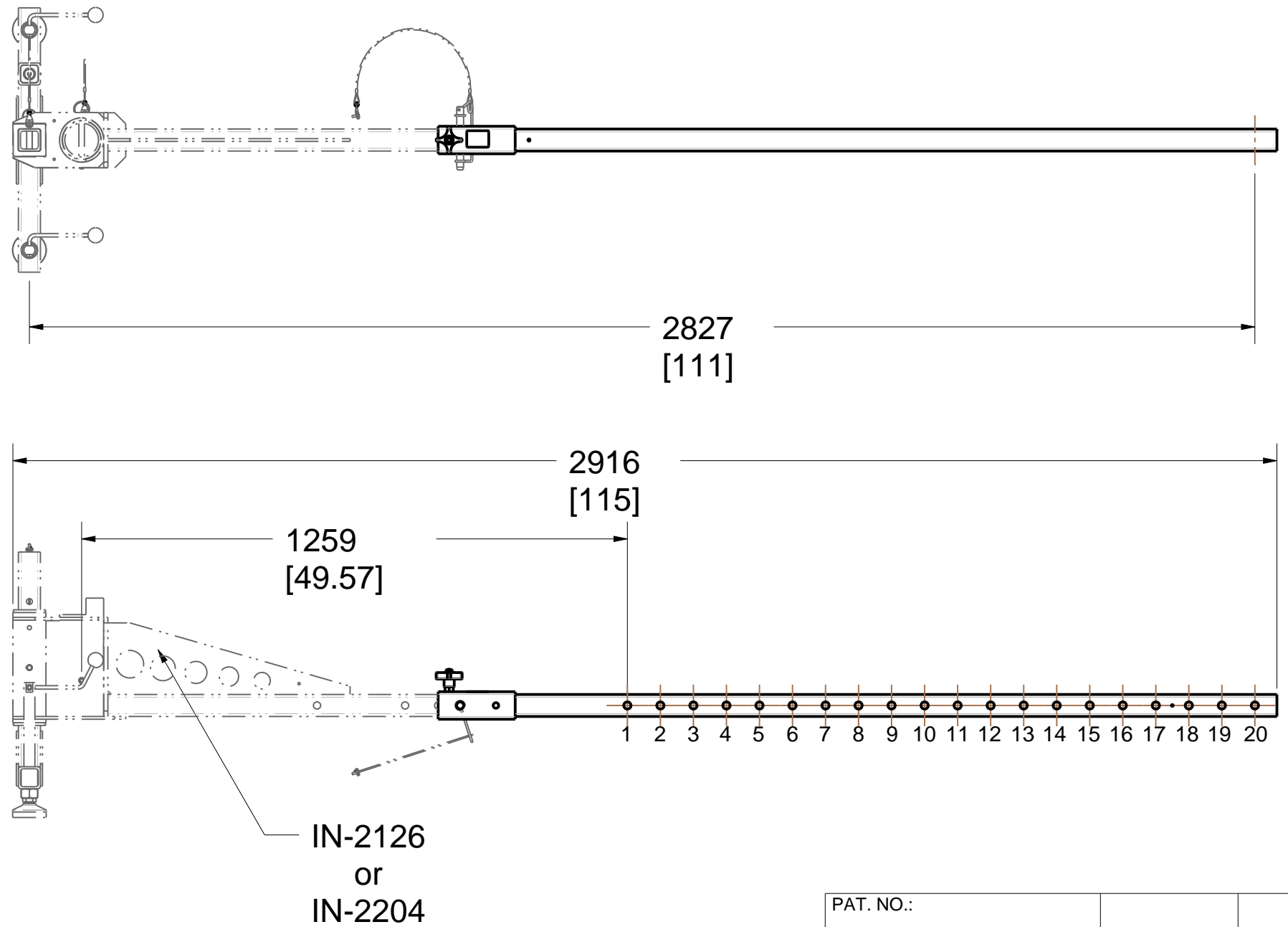

PAT. NO.:		©20/11/2008	©
PRODUITS DE SERVICE PUBLICS INNOVA INC. INNOVA PUBLIC UTILITY PRODUCTS INC.			
<small>© 9105-0732 QUEBEC INC. and under exclusive license to INNOVA PUBLIC UTILITY PRODUCTS INC. (hereafter « INNOVA »). All rights reserved. Protected under the Copyright Act of Canada and international treaties and agreements regarding copyrights. Violators are subject to prosecution and other legal recourses for infringement. Any reproduction, adaptation or other use or disclosure whatsoever, in totality or in part, and in any form or by any means whatsoever, strictly forbidden and requires the prior written approval of INNOVA. All data is the exclusive property of 9105-0732 QUEBEC INC. and under exclusive license to INNOVA and cannot be used nor disclosed in any way either without the prior written approval of INNOVA.</small>			
WEIGHT:	TITLE:		
30 Lb	1829mm (72") Hitch mount extension		
14 Kg			
COLOR:	MATERIAL:	SHEET(S):	PROJECT:
Zinc Plated	Steel	2 / 4	A2126-09

SPECIFICATIONS

This equipment is considered as part of a personal fall arrest system (PFAS).

It is only to be used in conjunction with a personal fall arrest system that limits the maximum arrest force (MAF).

Working load limit (WLL): 1,112 N (250 lbf)
 Max design capacity: 11,121 N (2,500 lbf)

Note: The structure must meet the maximum design capacity.

STANDARDS

Meets the following standards:
 OSHA Personal fall arrest system - 1910.66 App C
 ANSI Safety requirements for personal fall arrest system, subsystems and components Z359.1 (R1999) / 2007
 CAN/CSA Fall arresters, vertical lifelines, and rails Z259.2.1-98
 CE EN 795: 2012 Type B

MATERIAL AND CONSTRUCTION

Tubes: HSS Steel A500
 Pin: Steel zinc plated
 Handle: Black Thermoplastic
 Lanyard : Nylon covered Stainless Steel Cable
 Finish : Clear Zinc plated, ASTM B-633-11, Type V, SC3.
 Welding Certification : CSA W59 & W47.1

RESTRICTIONS

This product is to be used only with products approved by Innova Public Utility Products inc.

****The positioning pins must always be in place when manoeuvring personnel. Otherwise, serious injuries may occur.**

Periodic inspections of hardware must be done. In the occurrence of a fall or the safety of the equipment is in doubt, equipment must be immediately removed from service and inspected by qualified personnel before reuse.

Product number: A2126-09

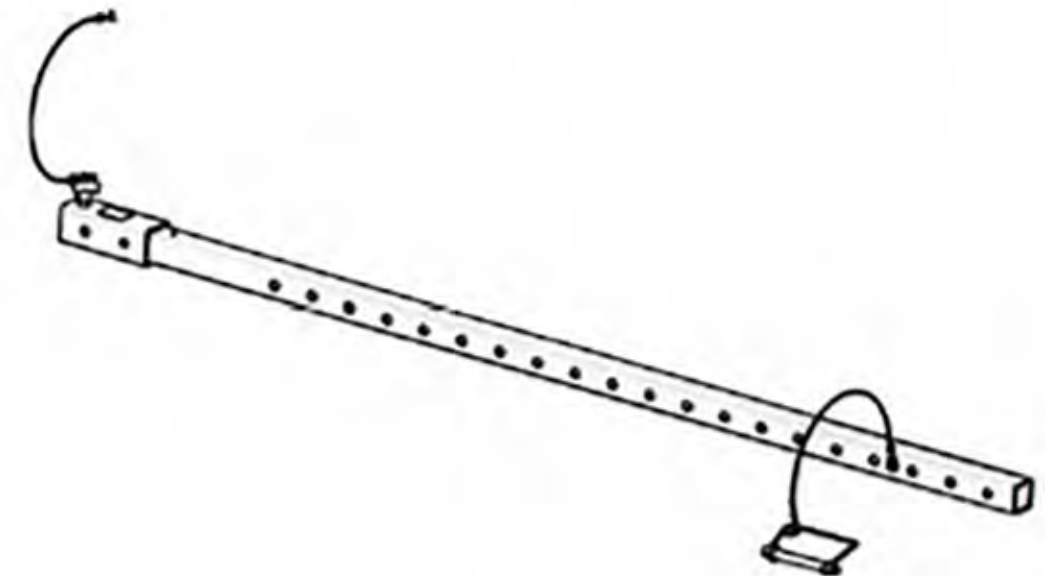

PAT. NO.:		©2011/2008	©
PRODUITS DE SERVICE PUBLICS INNOVA INC. INNOVA PUBLIC UTILITY PRODUCTS INC.			
<small>© INNOVA PUBLIC UTILITY PRODUCTS INC. and/or other holders of the INNOVA PUBLIC UTILITY PRODUCTS INC. (Innova) or INNOVA or its registered trademarks. All rights reserved. No part of this document may be reproduced, stored in a retrieval system, or transmitted, in any form or by any means, electronic, mechanical, photocopying, recording, or by any information storage and retrieval system, without the prior written permission of INNOVA PUBLIC UTILITY PRODUCTS INC. or its authorized representatives. All other trademarks are the property of their respective owners.</small>			
WEIGHT:	WLL:		
30 Lb	1829mm (72") Hitch mount extension		
14 Kg			
COLOR:	MATERIAL:	SIZE:	PRODUCT:
Zinc Plated	Steel	3 / 4	A2126-09

Product number: A2126-09

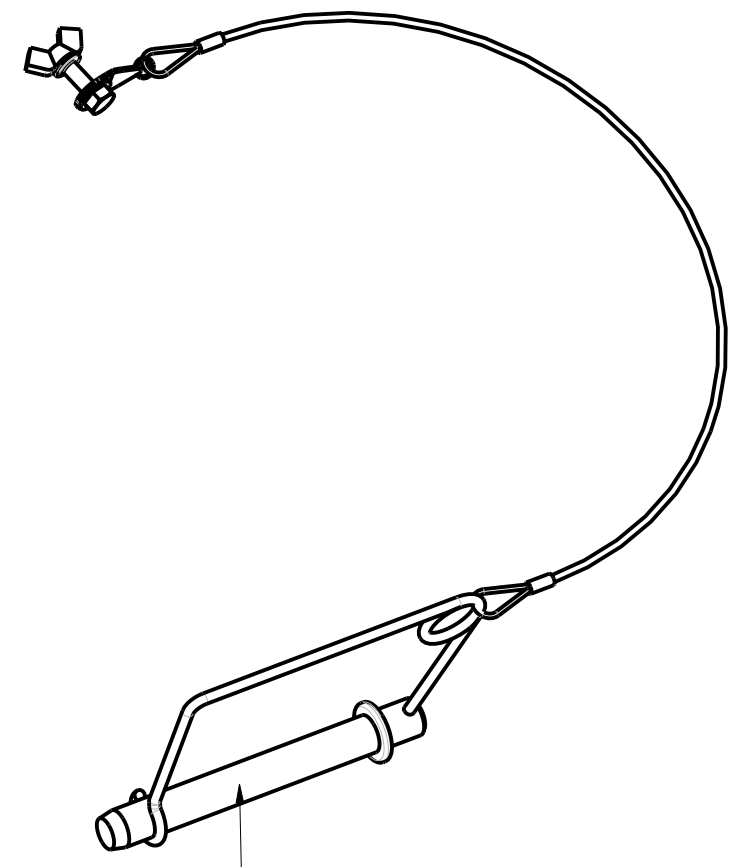
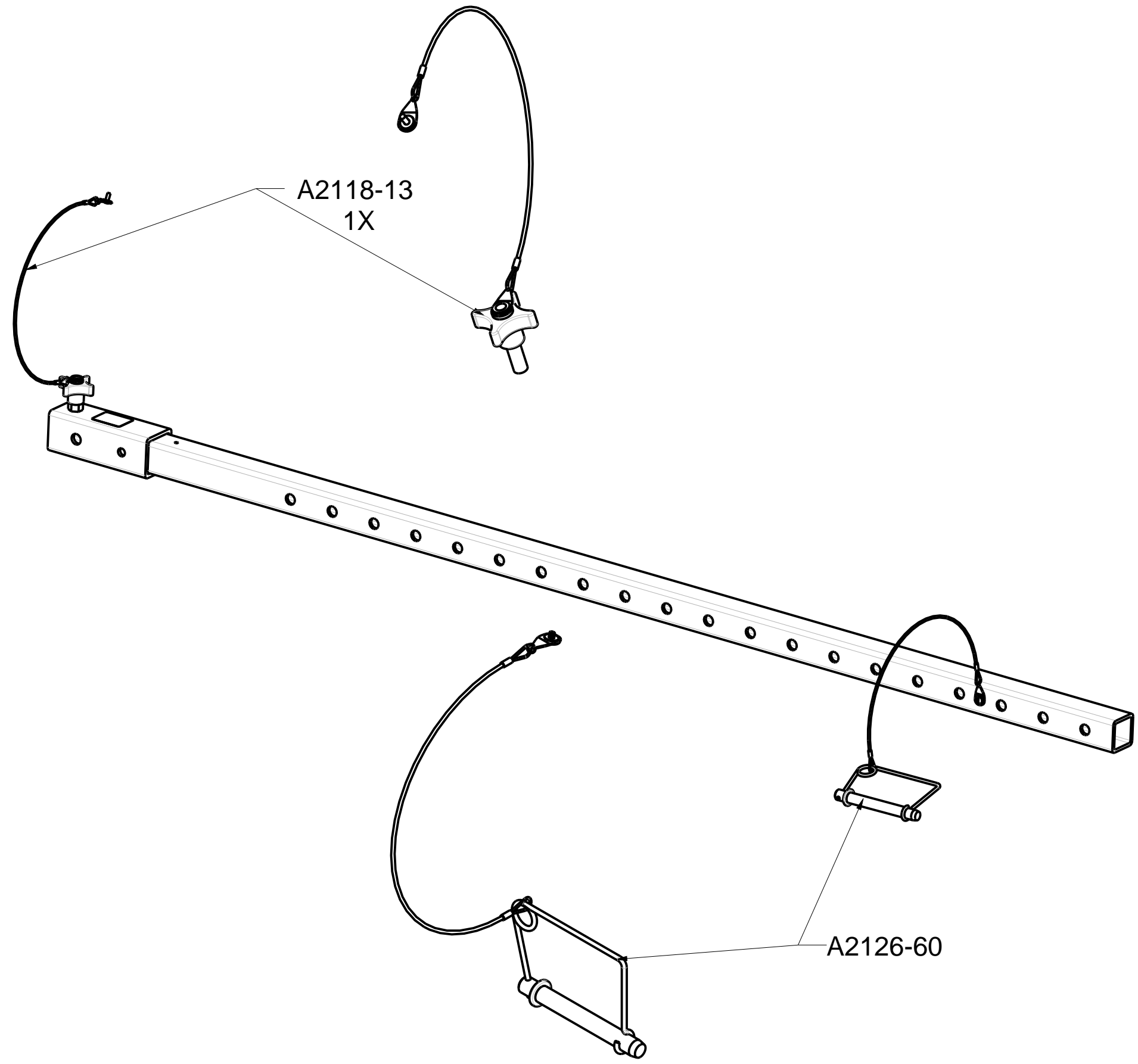

PAT. NO.:		©20/11/2008	©
PRODUITS DE SERVICE PUBLICS INNOVA INC. INNOVA PUBLIC UTILITY PRODUCTS INC.			
© 9105-0732 QUEBEC INC. and under exclusive license to INNOVA PUBLIC UTILITY PRODUCTS INC., (hereafter « INNOVA »). All rights reserved. Protected under the Copyright Act of Canada and international treaties and agreements regarding copyrights. Violators are subject to prosecution and other legal recourses for infringement. Any reproduction, adaptation or other use or disclosure whatsoever, in totality or in part, and in any form or by any means whatsoever, strictly forbidden and requires the prior written approval of INNOVA. All data is the exclusive property of 9105-0732 QUEBEC INC. and under exclusive license to INNOVA and cannot be used nor disclosed in any way either without the prior written approval of INNOVA.			
WEIGHT:	TITLE:		
30 Lb	1829mm (72") Hitch mount extension		
14 Kg			
COLOR:	MATERIAL:	SHEET(S):	PROJECT:
Zinc Plated	Steel	4 / 4	A2126-09