

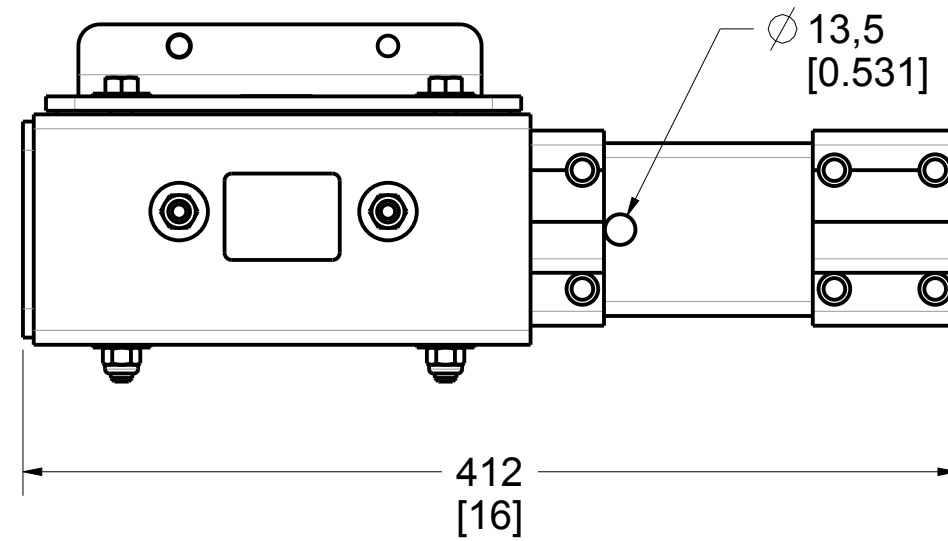

Product number: **A2237-06**

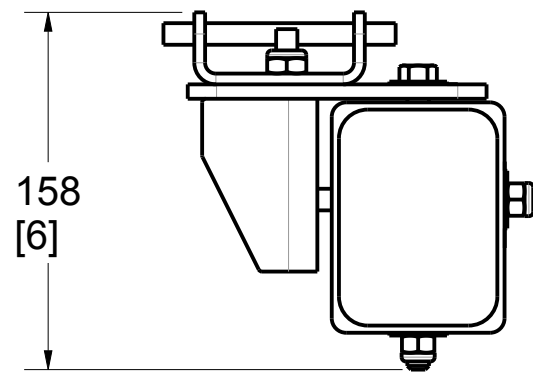
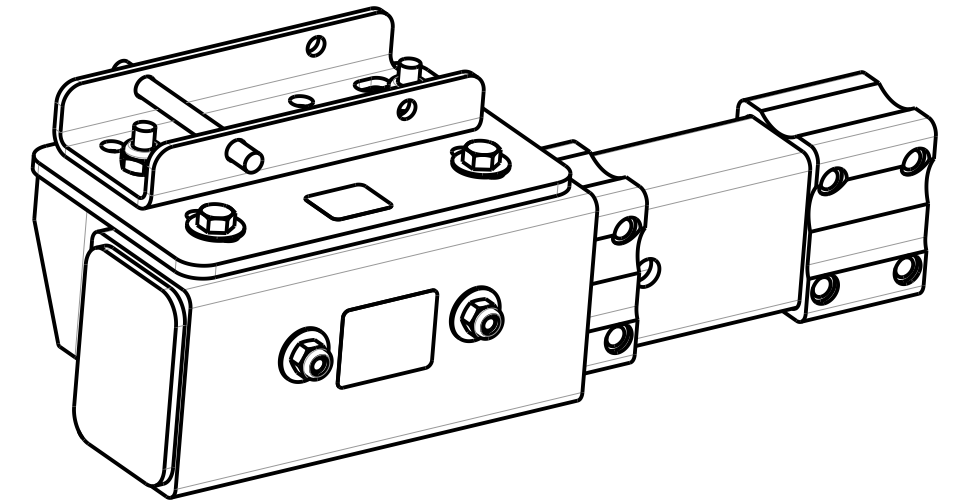
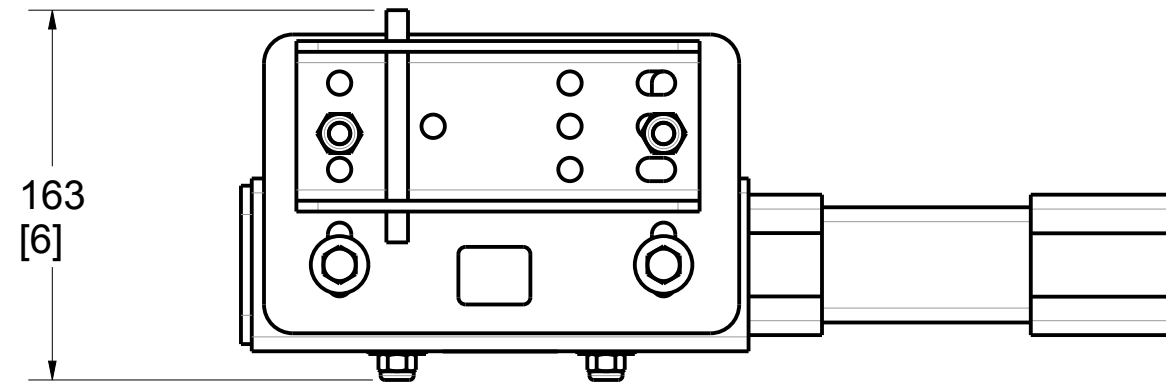

PAT.NO.:				
PRODUITS DE SERVICE PUBLICS INNOVA INC. INNOVA PUBLIC UTILITY PRODUCTS INC.				
© 9105-0732 QUEBEC INC. and under exclusive license to INNOVA PUBLIC UTILITY PRODUCTS INC., (hereafter « INNOVA »). All rights reserved. Protected under the Copyright Act of Canada and international treaties and agreements regarding copyrights. Violators are subject to prosecution and other legal recourses for infringement. Any reproduction, adaptation or other use or disclosure whatsoever, in totality or in part, and in any form or by any means whatsoever, strictly forbidden and requires the prior written approval of INNOVA. All data is the exclusive property of 9105-0732 QUEBEC INC. and under exclusive license to INNOVA and cannot be used nor disclosed in any way either without the prior written approval of INNOVA®.				
WEIGHT:	TITLE:			
15.0 lb	REMOVABLE WINCH ADAPTER			
6.8 kg	FOR DAVIT ARM IN-2237			
COLOR:	Material:	SHEET(S):	PROJET:	Rev.
YELLOW XTIRPA	ALUMINUM	1 / 3	A2237-06	01

8

7

6

5

4

3

2

1

Product number: A2237-06

H
G
F
E
D
C
B
A

H
G
F
E
D
C
B
A

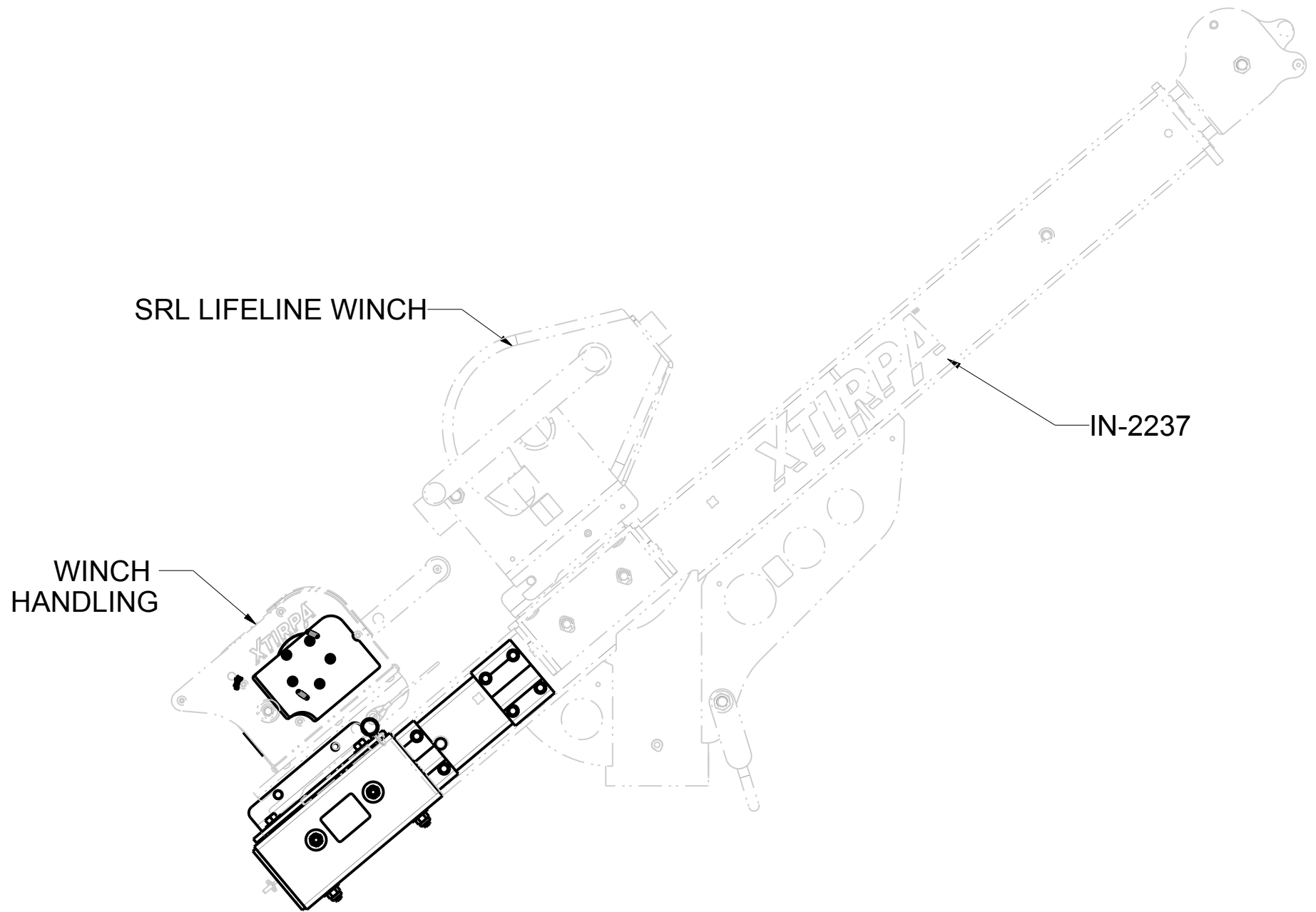

PAT.NO.:	

PRODUITS DE SERVICE PUBLICS INNOVA INC.
INNOVA PUBLIC UTILITY PRODUCTS INC.

© 9105-0732 QUEBEC INC. and under exclusive license to INNOVA PUBLIC UTILITY PRODUCTS INC., (hereafter « INNOVA »). All rights reserved. Protected under the Copyright Act of Canada and international treaties and agreements regarding copyrights. Violators are subject to prosecution and other legal recourses for infringement. Any reproduction, adaptation or other use or disclosure whatsoever, in totality or in part, and in any form or by any means whatsoever, strictly forbidden and requires the prior written approval of INNOVA. All data is the exclusive property of 9105-0732 QUEBEC INC. and under exclusive license to INNOVA and cannot be used nor disclosed in any way either without the prior written approval of INNOVA».

WEIGHT:	TITLE:			
15.0 lb	REMOVABLE WINCH ADAPTER FOR DAVIT ARM IN-2237			
6.8 kg				

COLOR:	Material:	SHEET(S):	PROJET:	Rev.
YELLOW XTIRPA	ALUMINUM	2 / 3	A2237-06	01

8

7

6

5

4

3

2

1

8

7

6

5

4

3

2

1

Product number: **A2237-06**

H

G

F

E

D

C

B

A

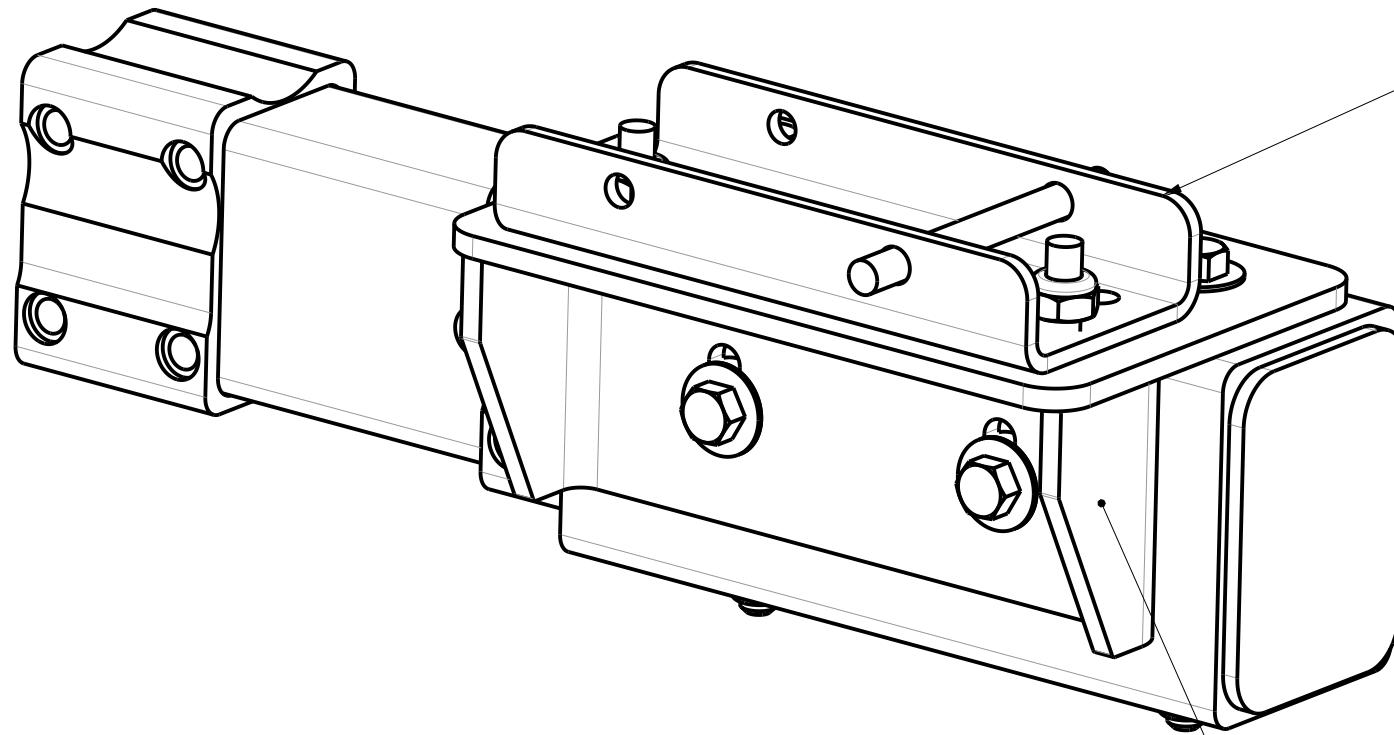

A2002-31
OR
A2002-31G (MARINE)

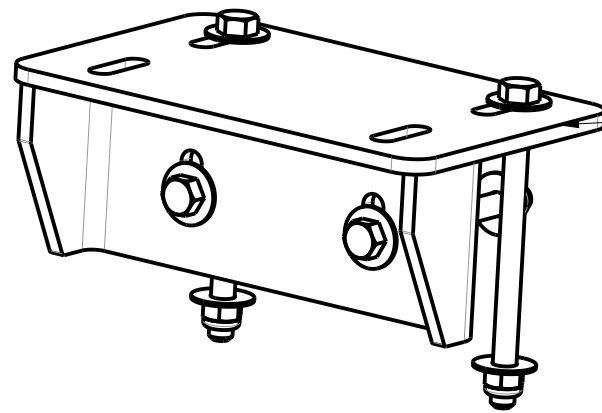
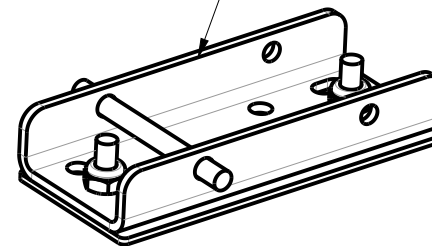

A2237-13
OR
A2237-13G (MARINE)

ALSO AVAILABLE:
GRADE MARINE A2237-06M
ANODIZED A2237-06P
GRADE MARINE ANODIZED A2237-06PM

PAT.NO.:				
PRODUITS DE SERVICE PUBLICS INNOVA INC. INNOVA PUBLIC UTILITY PRODUCTS INC.				
<small>© 9105-0732 QUEBEC INC. and under exclusive license to INNOVA PUBLIC UTILITY PRODUCTS INC., (hereafter « INNOVA »). All rights reserved. Protected under the Copyright Act of Canada and international treaties and agreements regarding copyrights. Violators are subject to prosecution and other legal recourses for infringement. Any reproduction, adaptation or other use or disclosure whatsoever, in totality or in part, and in any form or by any means whatsoever, strictly forbidden and requires the prior written approval of INNOVA. All data is the exclusive property of 9105-0732 QUEBEC INC. and under exclusive license to INNOVA and cannot be used nor disclosed in any way either without the prior written approval of INNOVA.</small>				
WEIGHT:	TITLE:			
15.0 lb	REMOVABLE WINCH ADAPTER			
6.8 kg	FOR DAVIT ARM IN-2237			
COLOR:	Material:	SHEET(S):	PROJET:	Rev.
YELLOW XTIRPA	ALUMINUM	3 / 3	A2237-06	01

8

7

6

5

4

3

2

1