

Product number: IN-2313

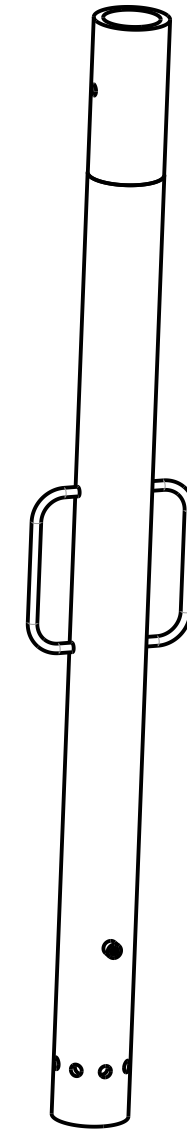

PAT.NO.:

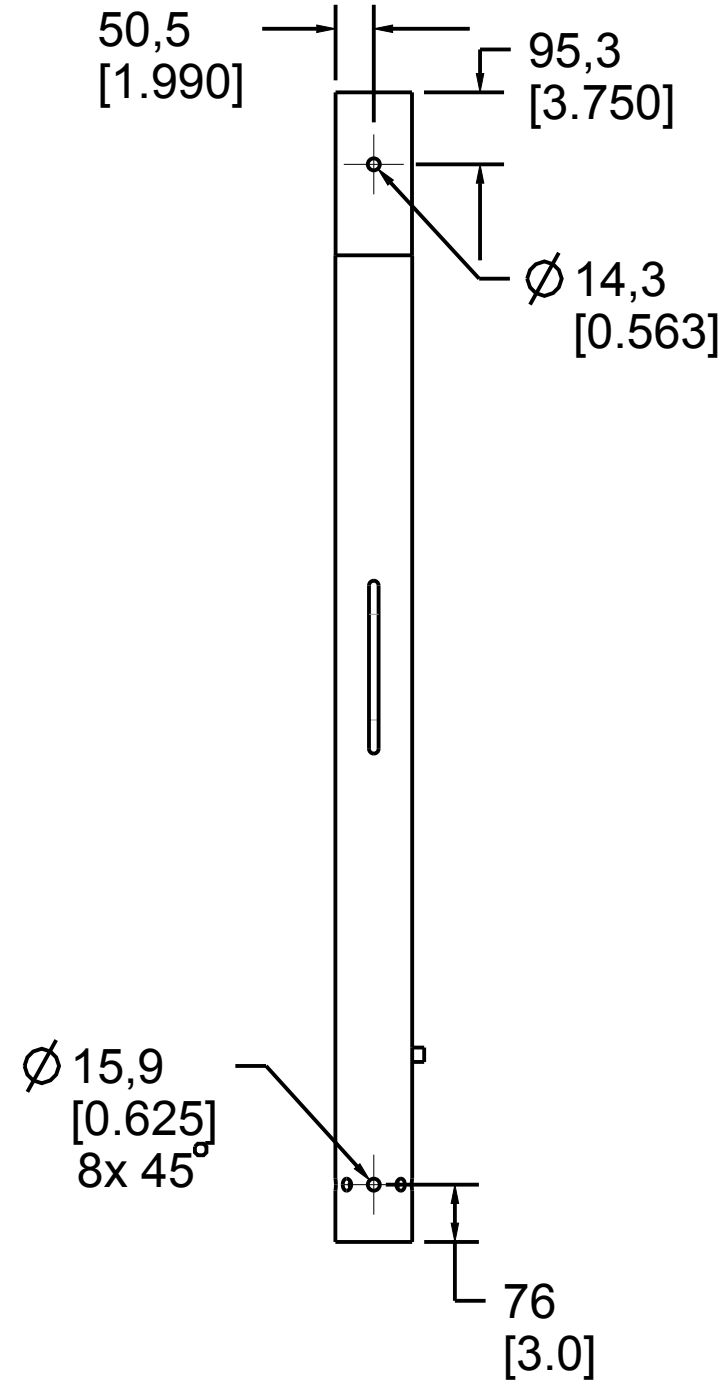
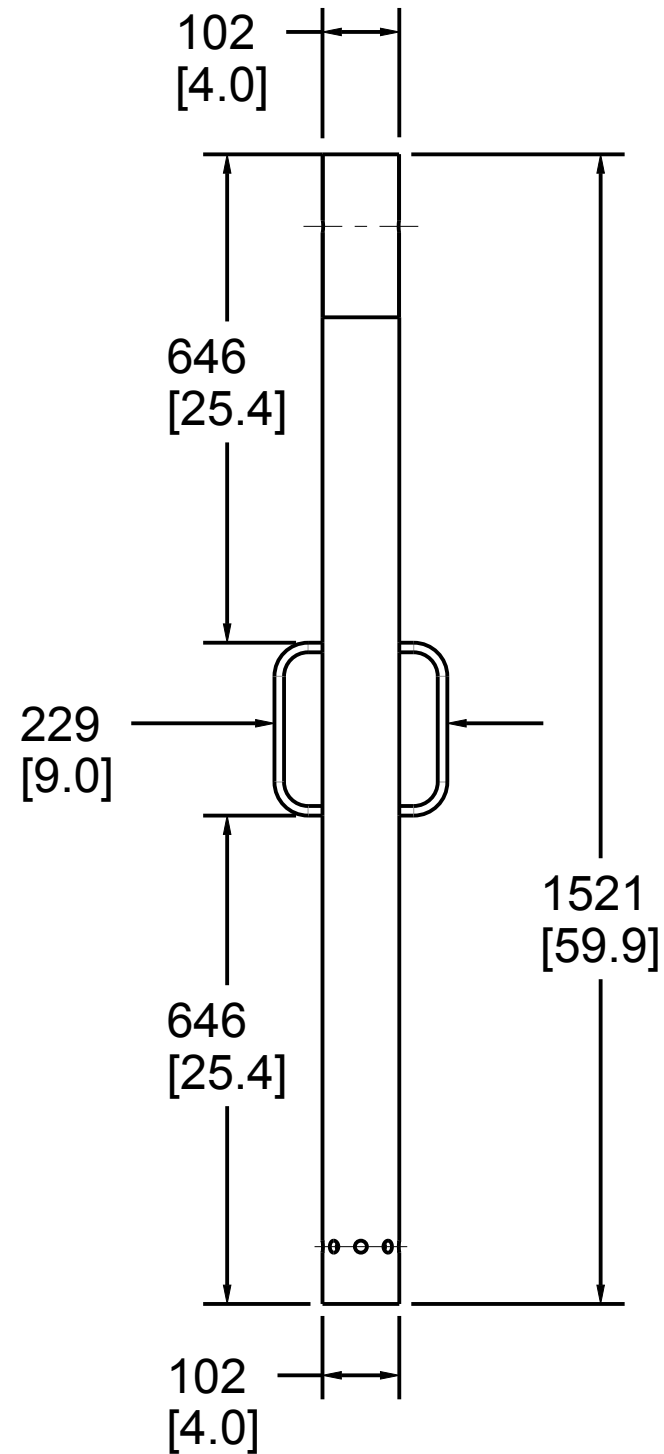
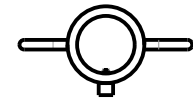

PRODUITS DE SERVICE PUBLICS INNOVA INC.
INNOVA PUBLIC UTILITY PRODUCTS INC.

© 9105-0732 QUEBEC INC. and under exclusive license to INNOVA PUBLIC UTILITY PRODUCTS INC., (hereafter « INNOVA »). All rights reserved. Protected under the Copyright Act of Canada and international treaties and agreements regarding copyrights. Violators are subject to prosecution and other legal recourses for infringement. Any reproduction, adaptation or other use or disclosure whatsoever, in totality or in part, and in any form or by any means whatsoever, strictly forbidden and requires the prior written approval of INNOVA. All data is the exclusive property of 9105-0732 QUEBEC INC. and under exclusive license to INNOVA and cannot be used nor disclosed in any way either without the prior written approval of INNOVA.

WEIGHT:

TITLE:

34.0 Lb

102mm (4") Mast for Davit-Arm IN-2237

15.4 Kg

1524mm (60") height

COLOR:

Yellow
XTIRPA

Material:

Aluminum

SHEET(S):

1 / 4

PROJET:

IN-2313

Rev.

05

Product number: **IN-2313**

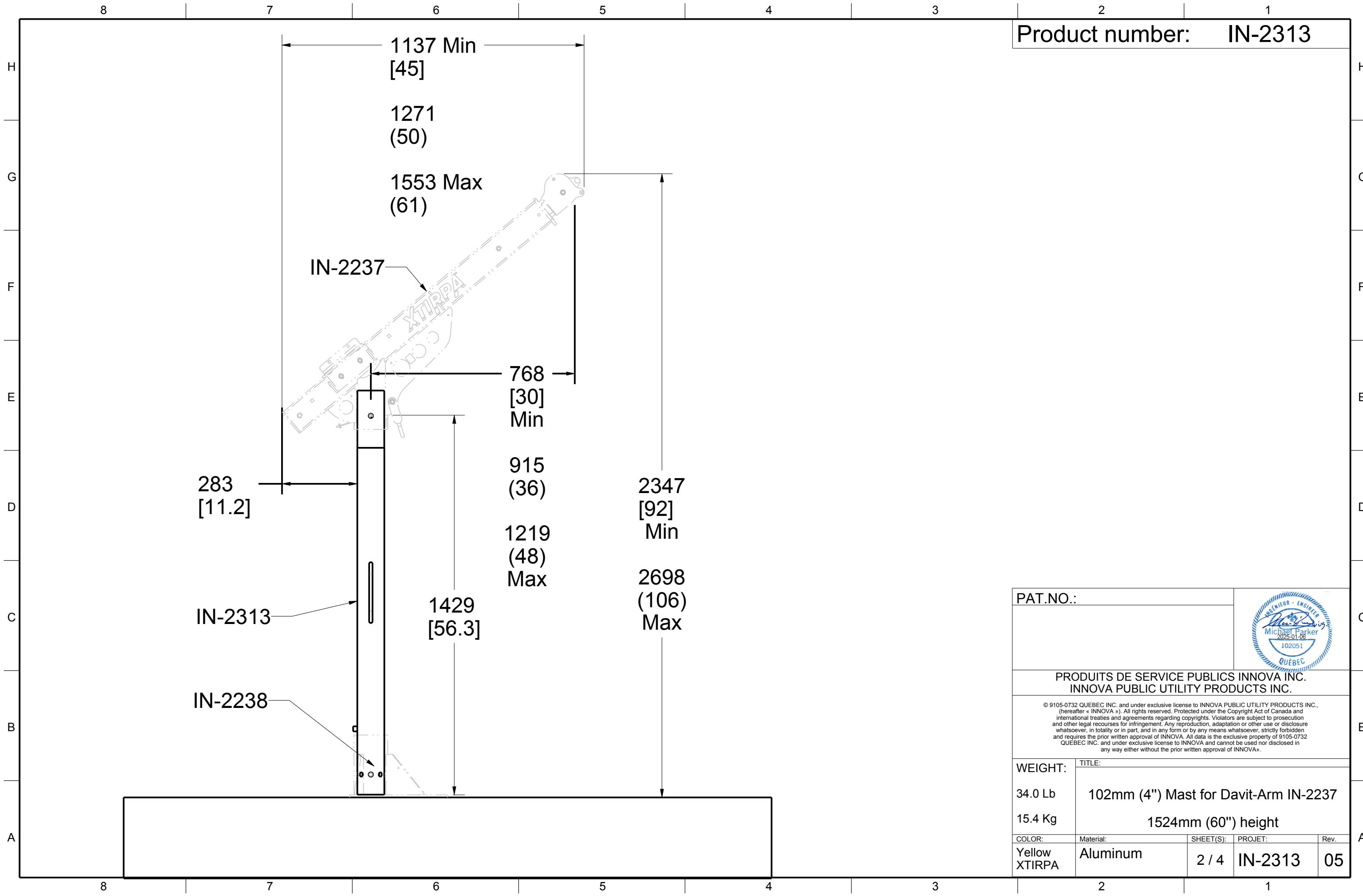

PAT.NO.:				
PRODUITS DE SERVICE PUBLICS INNOVA INC. INNOVA PUBLIC UTILITY PRODUCTS INC.				
© 9105-0732 QUEBEC INC. and under exclusive license to INNOVA PUBLIC UTILITY PRODUCTS INC., (hereafter « INNOVA »). All rights reserved. Protected under the Copyright Act of Canada and international treaties and agreements regarding copyrights. Violators are subject to prosecution and other legal recourses for infringement. Any reproduction, adaptation or other use or disclosure whatsoever, in totality or in part, and in any form or by any means whatsoever, strictly forbidden and requires the prior written approval of INNOVA. All data is the exclusive property of 9105-0732 QUEBEC INC. and under exclusive license to INNOVA and cannot be used nor disclosed in any way either without the prior written approval of INNOVA.				
WEIGHT:	TITLE:			
34.0 Lb	102mm (4") Mast for Davit-Arm IN-2237			
15.4 Kg	1524mm (60") height			
COLOR:	Material:	SHEET(S):	PROJET:	Rev.
Yellow XTIRPA	Aluminum	2 / 4	IN-2313	05

SPECIFICATIONS

H This equipment is considered as part of a personal fall arrest system (PFAS) with a maximum working capacity of 164 Kg (360 lb).

It is only to be used in conjunction with a personal fall arrest system that limits the maximum arrest force (MAF).

G Max Working load (mass):
 With Davit-Arm IN-2237: 164 kg (360 lb)
 Max working moment with Davit-Arm IN-2237: 1,952 N-m (17,280 lbf-in)

Max design capacity: with Davit-Arm IN-2237: 16,014 N (3,600 lbf)
 Max design moment with Davit-Arm IN-2237: 19,524 N-m (172,800 lbf-in)

STANDARDS

Name	Classification	Year	Users
AS / NZS 5532	Freefall Arrest	2013	1
ANSI Z359.18	D	2017	1
CSA Z259.15	AD	2022	1
OSHA 1910.140			1
OSHA 1926.502			1
EN 795	A,B,E	2012	1
TS 16415		2013	3

MATERIAL AND CONSTRUCTION

Mast : Aluminum 6061-T6
 Handle : Aluminum 6061-T6
 Welding certification: CSA W47,2M
 Surface Finishing : Yellow XTIRPA

RESTRICTIONS

This equipment is to be used only with products approved by Innova Public Utility Products Inc.

B This equipment must always be operated on a level surface.

Ensure that all hardware and connecting pins are properly installed before use.

A In the occurrence of a fall or the safety of the equipment is in doubt, the equipment must be immediately removed from service and inspected by qualified personnel before reuse.

Product number: **IN-2313**

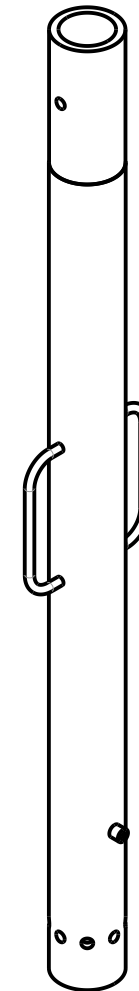

Also Available: Clear Anodized IN-2313P

PAT.NO.:				
PRODUITS DE SERVICE PUBLICS INNOVA INC. INNOVA PUBLIC UTILITY PRODUCTS INC.				
<small>© 9105-0732 QUEBEC INC. and under exclusive license to INNOVA PUBLIC UTILITY PRODUCTS INC., (hereafter « INNOVA »). All rights reserved. Protected under the Copyright Act of Canada and international treaties and agreements regarding copyrights. Violators are subject to prosecution and other legal recourses for infringement. Any reproduction, adaptation or other use or disclosure whatsoever, in totality or in part, and in any form or by any means whatsoever, strictly forbidden and requires the prior written approval of INNOVA. All data is the exclusive property of 9105-0732 QUEBEC INC. and under exclusive license to INNOVA and cannot be used nor disclosed in any way either without the prior written approval of INNOVA.</small>				
WEIGHT:	TITLE:			
34.0 Lb	102mm (4") Mast for Davit-Arm IN-2237			
15.4 Kg	1524mm (60") height			
COLOR:	Material:	SHEET(S):	PROJET:	Rev.
Yellow XTIRPA	Aluminum	3 / 4	IN-2313	05

8

7

6

5

4

3

2

1

Product number: IN-2313

H
G
F
E
D
C
B
A

H
G
F
E
D
C
B
A

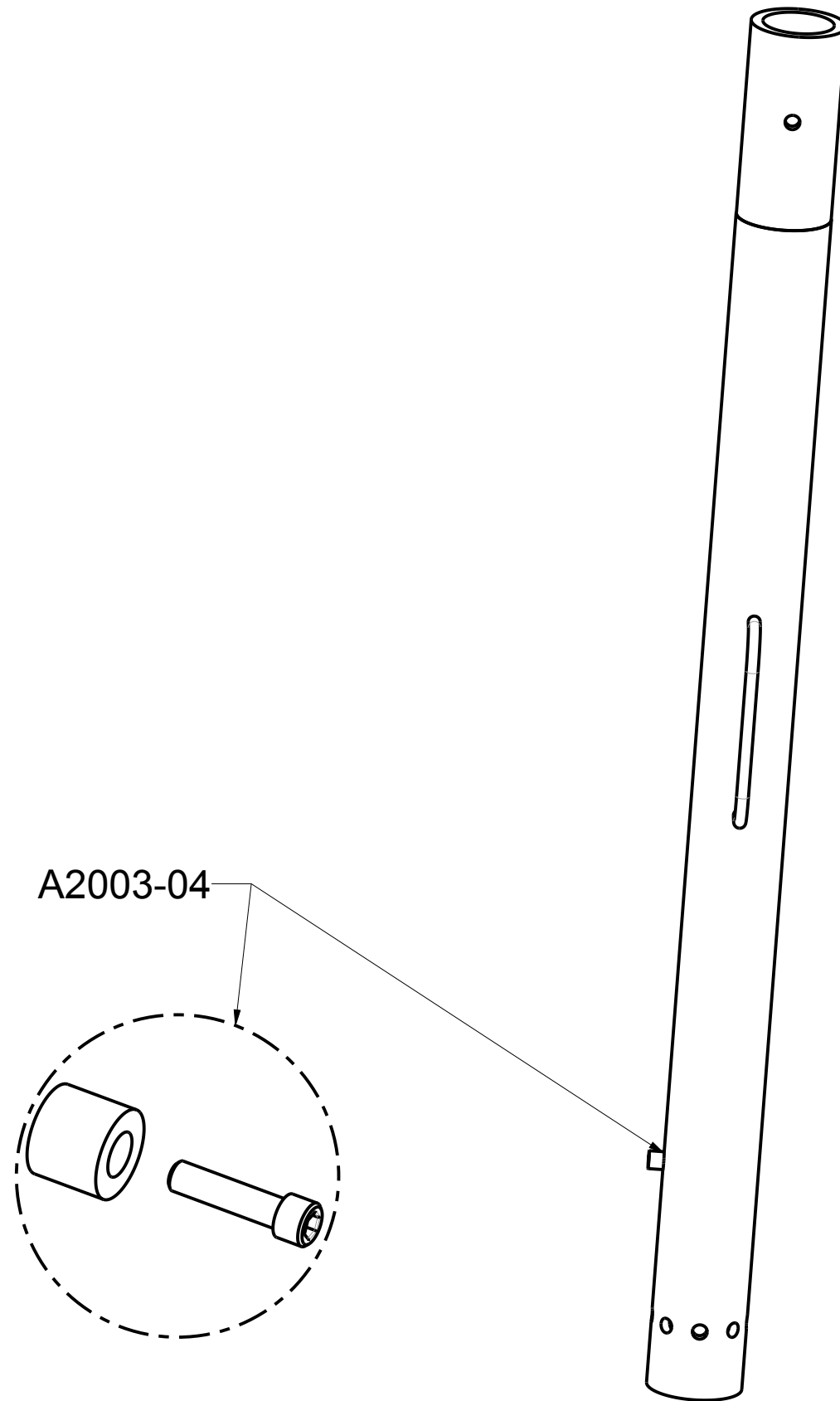

PAT.NO.:			
PRODUITS DE SERVICE PUBLICS INNOVA INC. INNOVA PUBLIC UTILITY PRODUCTS INC.			
© 9105-0732 QUEBEC INC. and under exclusive license to INNOVA PUBLIC UTILITY PRODUCTS INC., (hereafter « INNOVA »). All rights reserved. Protected under the Copyright Act of Canada and international treaties and agreements regarding copyrights. Violators are subject to prosecution and other legal recourses for infringement. Any reproduction, adaptation or other use or disclosure whatsoever, in totality or in part, and in any form or by any means whatsoever, strictly forbidden and requires the prior written approval of INNOVA. All data is the exclusive property of 9105-0732 QUEBEC INC. and under exclusive license to INNOVA and cannot be used nor disclosed in any way either without the prior written approval of INNOVA».			
WEIGHT:	TITLE:		
34.0 Lb	102mm (4") Mast for Davit-Arm IN-2237		
15.4 Kg	1524mm (60") height		
COLOR:	Material:	SHEET(S):	PROJET: Rev.
Yellow XTIRPA	Aluminum	4 / 4	IN-2313 05

8

7

6

5

4

3

2

1