

Product number: IN-2315

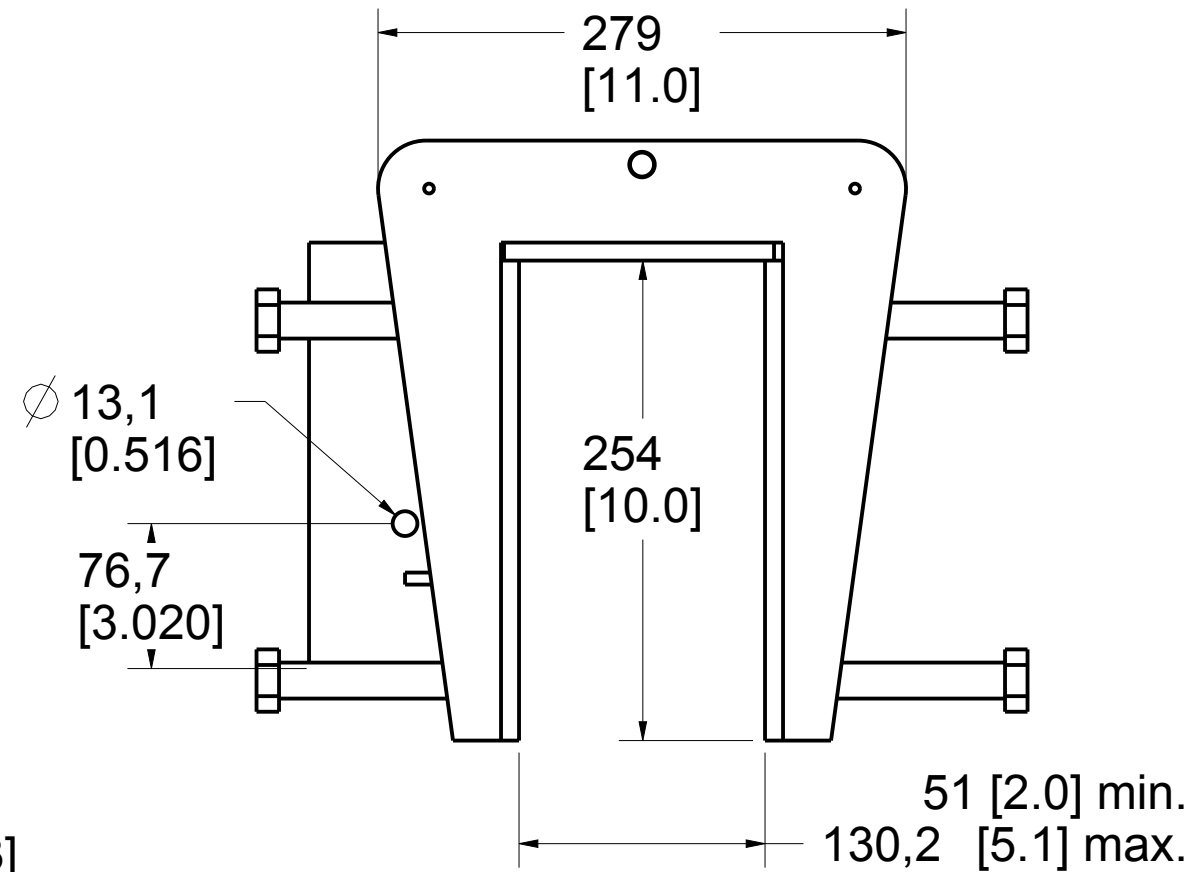
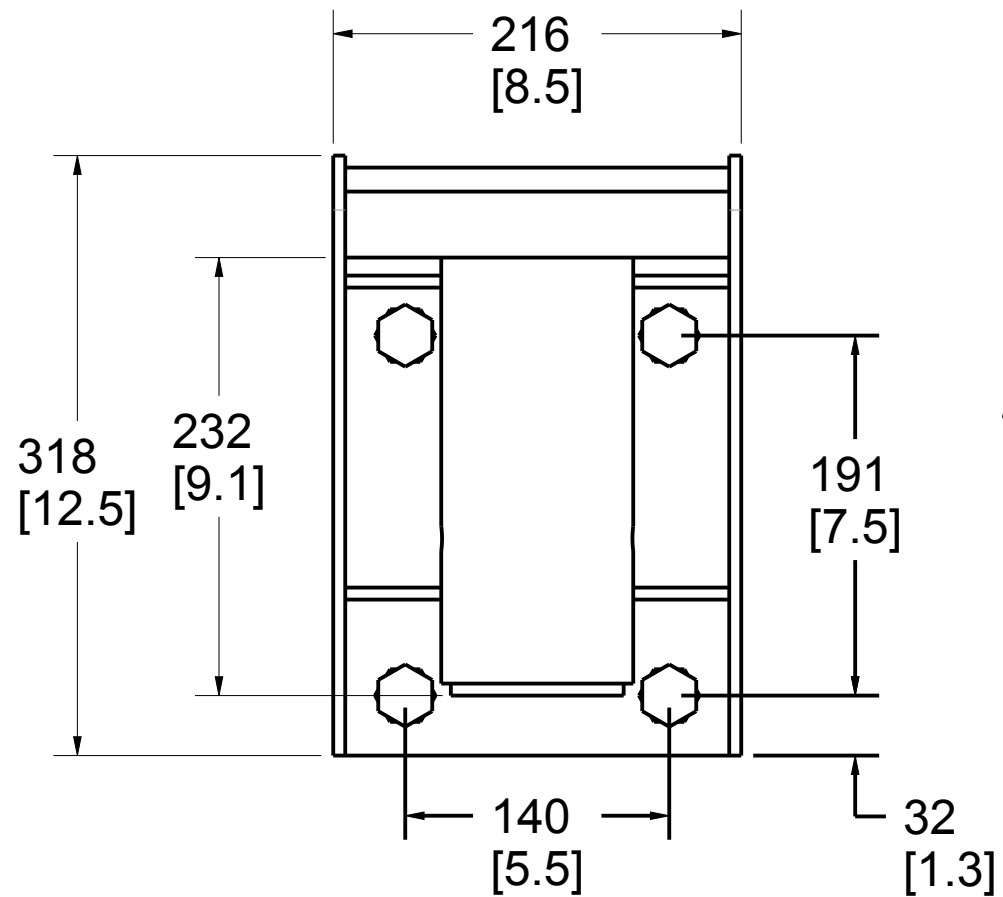
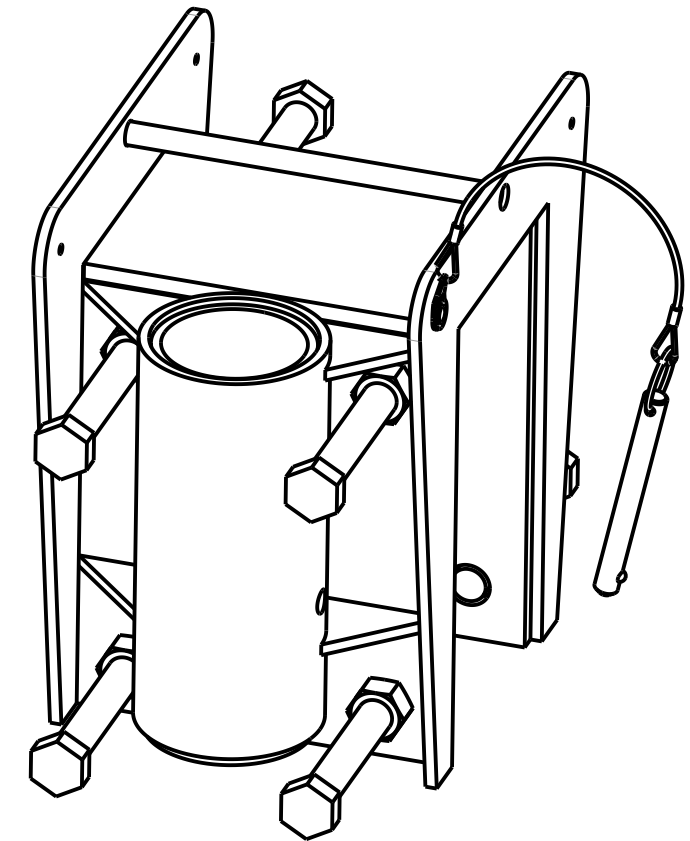
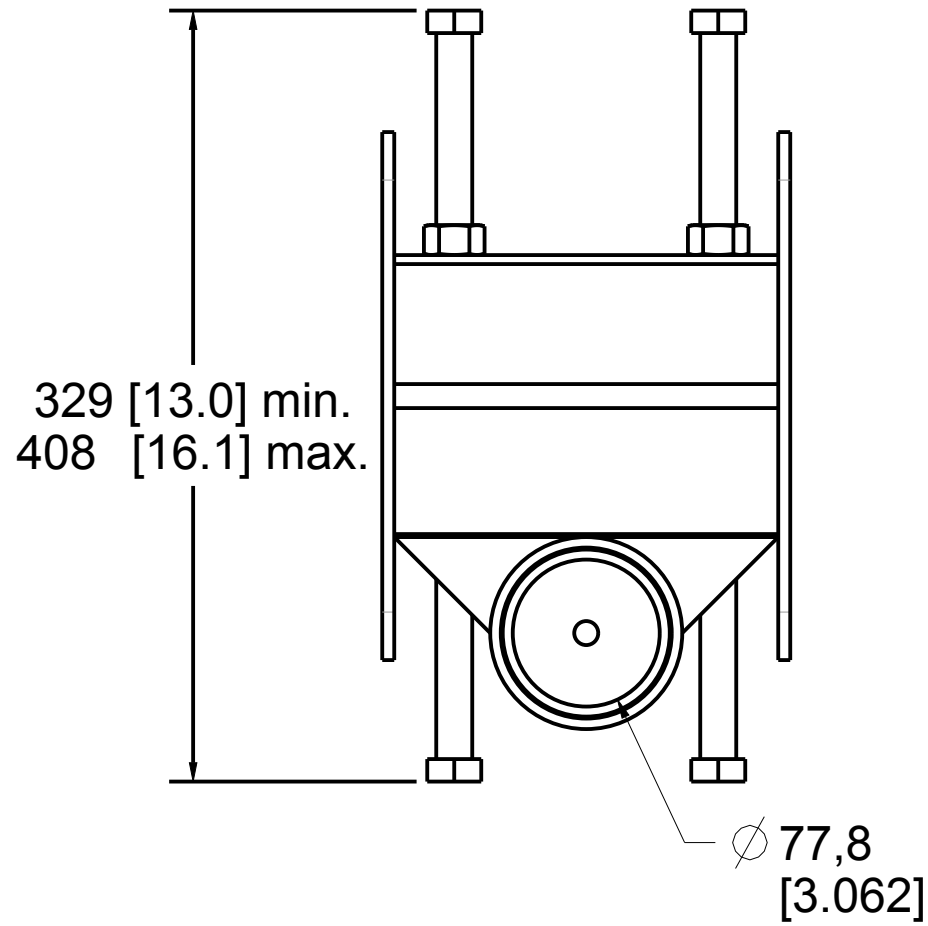

PAT.NO.:				
PRODUITS DE SERVICE PUBLICS INNOVA INC. INNOVA PUBLIC UTILITY PRODUCTS INC.				
<small>© 9105-0732 QUEBEC INC. and under exclusive license to INNOVA PUBLIC UTILITY PRODUCTS INC. (hereafter « INNOVA »). All rights reserved. Protected under the Copyright Act of Canada and international treaties and agreements regarding copyrights. Violators are subject to prosecution and other legal recourses for infringement. Any reproduction, adaptation or other use or disclosure whatsoever, in totality or in part, and in any form or by any means whatsoever, strictly forbidden and requires the prior written approval of INNOVA. All data is the exclusive property of 9105-0732 QUEBEC INC. and under exclusive license to INNOVA and cannot be used nor disclosed in any way either without the prior written approval of INNOVA.</small>				
WEIGHT:	TITLE:			
47.0 Lb	76mm (3") Barrel Adapter			
21.3 Kg	51mm-127mm (2"-5")			
COLOR:	Material:	SHEET(S):	PROJET:	Rev.
Zinc plated	Steel 44W	1 / 4	IN-2315	02

Product number: **IN-2315**

IMPORTANT:

Product shall only be used perpendicular to wall.

Wall recommendations:

Moment load : 9,8 kN•m (86 400 lbf•in)

Verticale load : 22,241 N (5 000 lbf)

N.B. It is the responsibility of the field engineer to assure installation compliance.

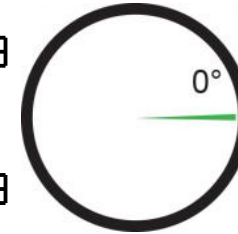
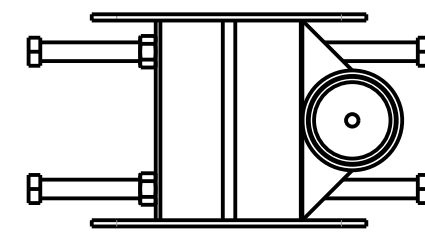

Permissible Working Angle

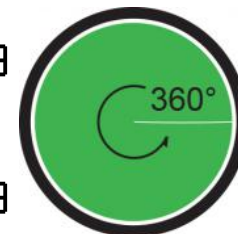
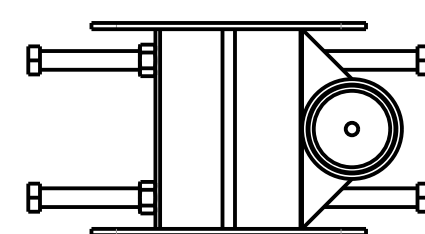

Permissible Angle of Recuperation

PAT.NO.:



PRODUITS DE SERVICE PUBLICS INNOVA INC.
INNOVA PUBLIC UTILITY PRODUCTS INC.

© 9105-0732 QUEBEC INC. and under exclusive license to INNOVA PUBLIC UTILITY PRODUCTS INC., (hereafter « INNOVA »). All rights reserved. Protected under the Copyright Act of Canada and international treaties and agreements regarding copyrights. Violators are subject to prosecution and other legal recourses for infringement. Any reproduction, adaptation or other use or disclosure whatsoever, in totality or in part, and in any form or by any means whatsoever, strictly forbidden and requires the prior written approval of INNOVA. All data is the exclusive property of 9105-0732 QUEBEC INC. and under exclusive license to INNOVA and cannot be used nor disclosed in any way either without the prior written approval of INNOVA.

WEIGHT:

47.0 Lb

21.3 Kg

TITLE:

76mm (3") Barrel Adapter

51mm-127mm (2"-5")

COLOR:

Zinc plated

Material:

Steel 44W

SHEET(S):

2 / 4

PROJET:

IN-2315

Rev.

02

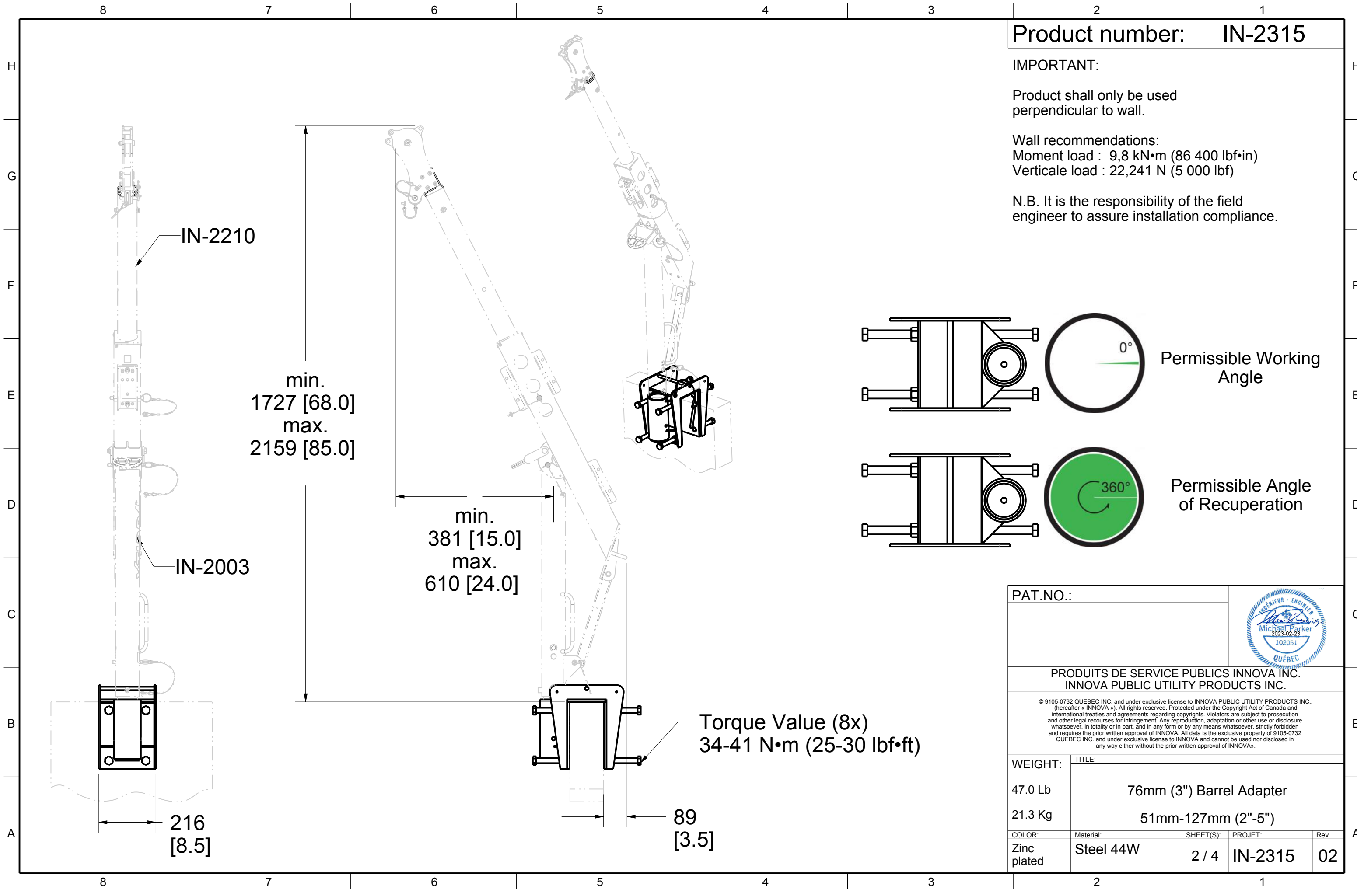

SPECIFICATIONS

H This equipment is considered as part of a personal fall arrest system (PFAS).

It is only to be used in conjunction with a personal fall arrest system that limits the maximum arrest force (MAF) to 6,0 kN.

G Working load limit (WLL) :	164 kg	(360 lb)
Minimum breaking strength :	16,0 kN	(3 600 lbf)
Maximum working moment :	0,6 kN•m	(5 400 lbf•in)
Maximum design moment :	6,1 kN•m	(54 000 lbf•in)

STANDARDS

F Name	Classification	Year	Users
ANSI Z359.1 (R1999)		2007	1
CSA Z259.2.1-1998		2011	1
OSHA 1910.66	App. C		1
E EN 795	B	2012	1
TS 16415		2013	2

MATERIAL AND CONSTRUCTION

D Structure:	Steel 44W
Welding certification:	CSA W59 & 47.1 , AWS D1.6
Surface finish:	Zinc Plated

RESTRICTIONS

C This product is to be used only with products approved by Innova Public Utility Products inc.

IMPORTANT :

B All adjustment pins shall be used at all times.
Always use the product perpendicular to the wall. It is not considered as a permanent structure.

**The positioning pins must always be in place when manoeuvring personnel. Otherwise, serious injuries may occur. Periodic inspections of hardware must be done. In the occurrence of a fall or the safety of the equipment is in doubt, equipment must be immediately removed from service and inspected by qualified personnel before reuse.

A ** This equipment must always be operated in a level position.

Product number: **IN-2315**

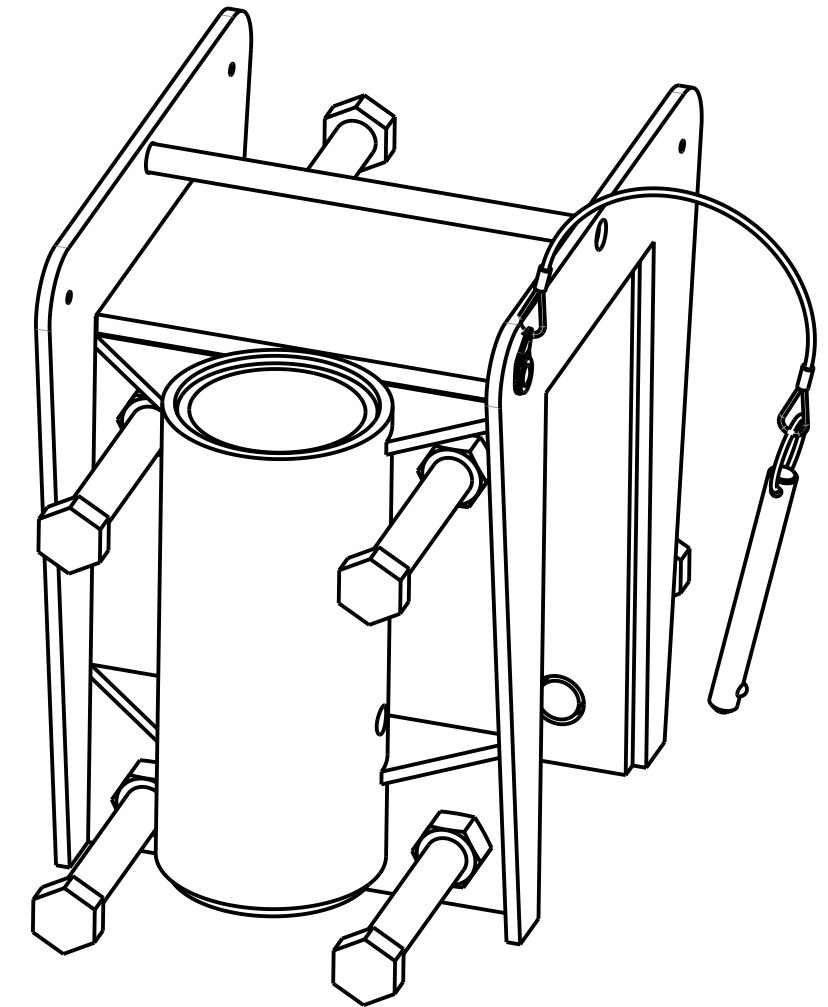

PAT.NO.:				
PRODUITS DE SERVICE PUBLICS INNOVA INC. INNOVA PUBLIC UTILITY PRODUCTS INC.				
<small>© 9105-0732 QUEBEC INC. and under exclusive license to INNOVA PUBLIC UTILITY PRODUCTS INC., (hereafter « INNOVA »). All rights reserved. Protected under the Copyright Act of Canada and international treaties and agreements regarding copyrights. Violators are subject to prosecution and other legal recourses for infringement. Any reproduction, adaptation or other use or disclosure whatsoever, in totality or in part, and in any form or by any means whatsoever, strictly forbidden and requires the prior written approval of INNOVA. All data is the exclusive property of 9105-0732 QUEBEC INC. and under exclusive license to INNOVA and cannot be used nor disclosed in any way either without the prior written approval of INNOVA».</small>				
WEIGHT:	TITLE:			
47.0 Lb	76mm (3") Barrel Adapter			
21.3 Kg	51mm-127mm (2"-5")			
COLOR:	Material:	SHEET(S):	PROJET:	Rev.
Zinc plated	Steel 44W	3 / 4	IN-2315	02

Product number: IN-2315

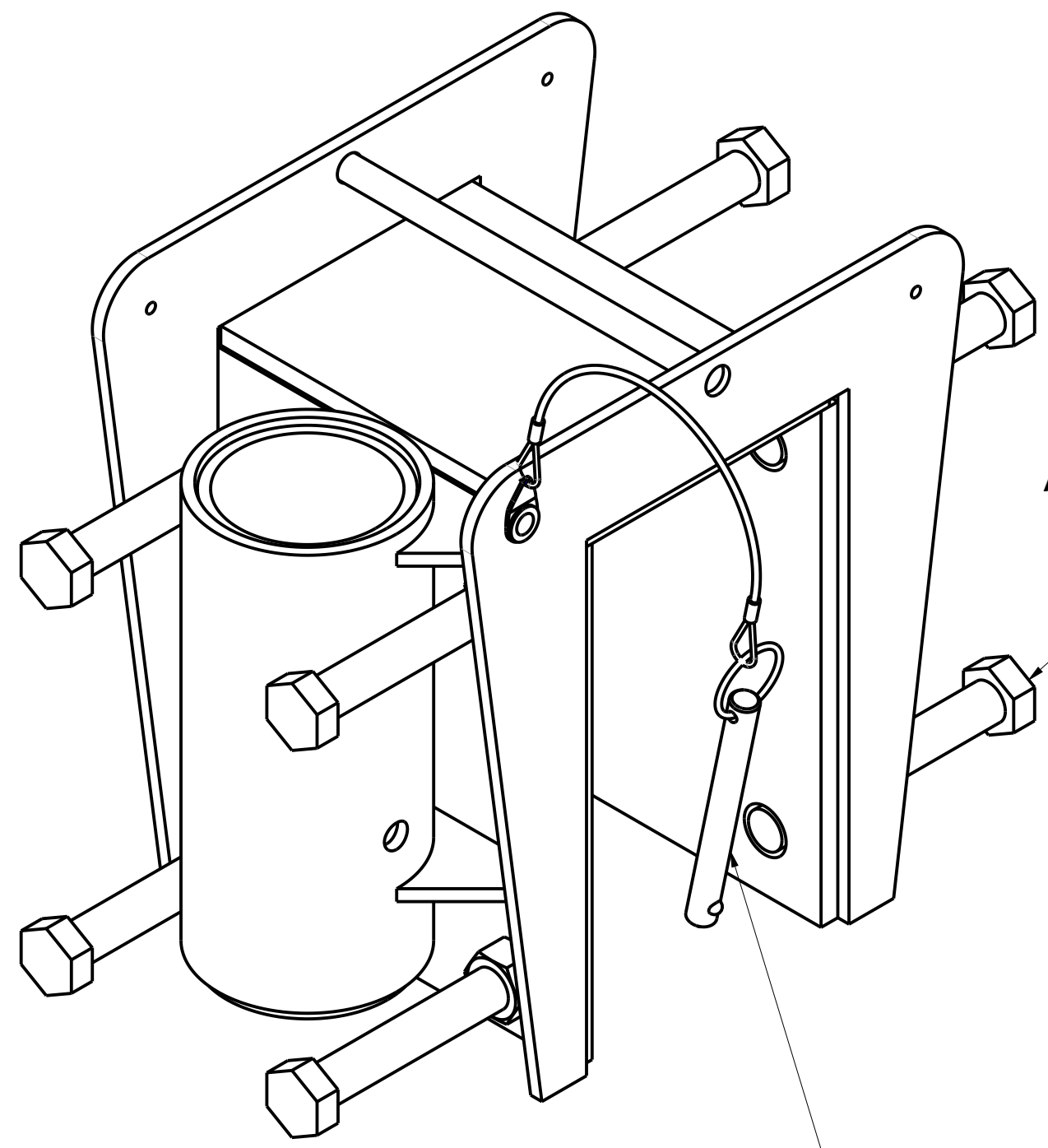

A2315-03

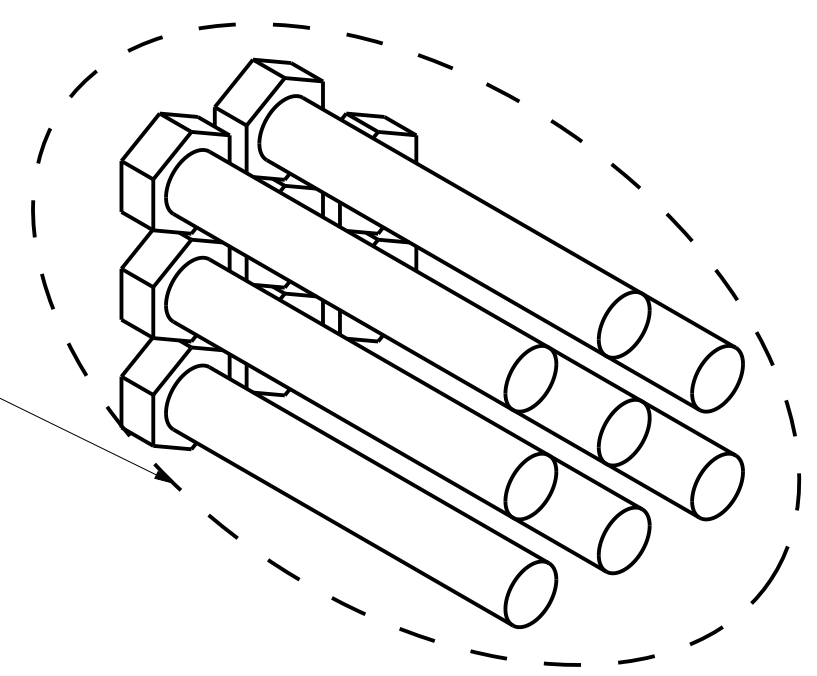

A2005-07

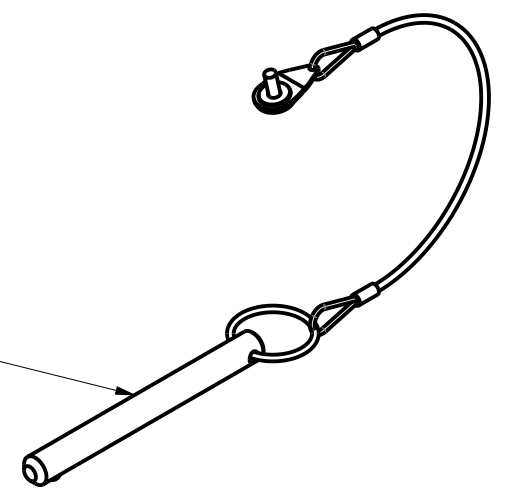

PAT.NO.:				
PRODUITS DE SERVICE PUBLICS INNOVA INC. INNOVA PUBLIC UTILITY PRODUCTS INC.				
<small>© 9105-0732 QUEBEC INC. and under exclusive license to INNOVA PUBLIC UTILITY PRODUCTS INC., (hereafter « INNOVA »). All rights reserved. Protected under the Copyright Act of Canada and international treaties and agreements regarding copyrights. Violators are subject to prosecution and other legal recourses for infringement. Any reproduction, adaptation or other use or disclosure whatsoever, in totality or in part, and in any form or by any means whatsoever, strictly forbidden and requires the prior written approval of INNOVA. All data is the exclusive property of 9105-0732 QUEBEC INC. and under exclusive license to INNOVA and cannot be used nor disclosed in any way either without the prior written approval of INNOVA.</small>				
WEIGHT:	TITLE:			
47.0 Lb	76mm (3") Barrel Adapter			
21.3 Kg	51mm-127mm (2"-5")			
COLOR:	Material:	SHEET(S):	PROJET:	Rev.
Zinc plated	Steel 44W	4 / 4	IN-2315	02