

Product number: **IN-2380**

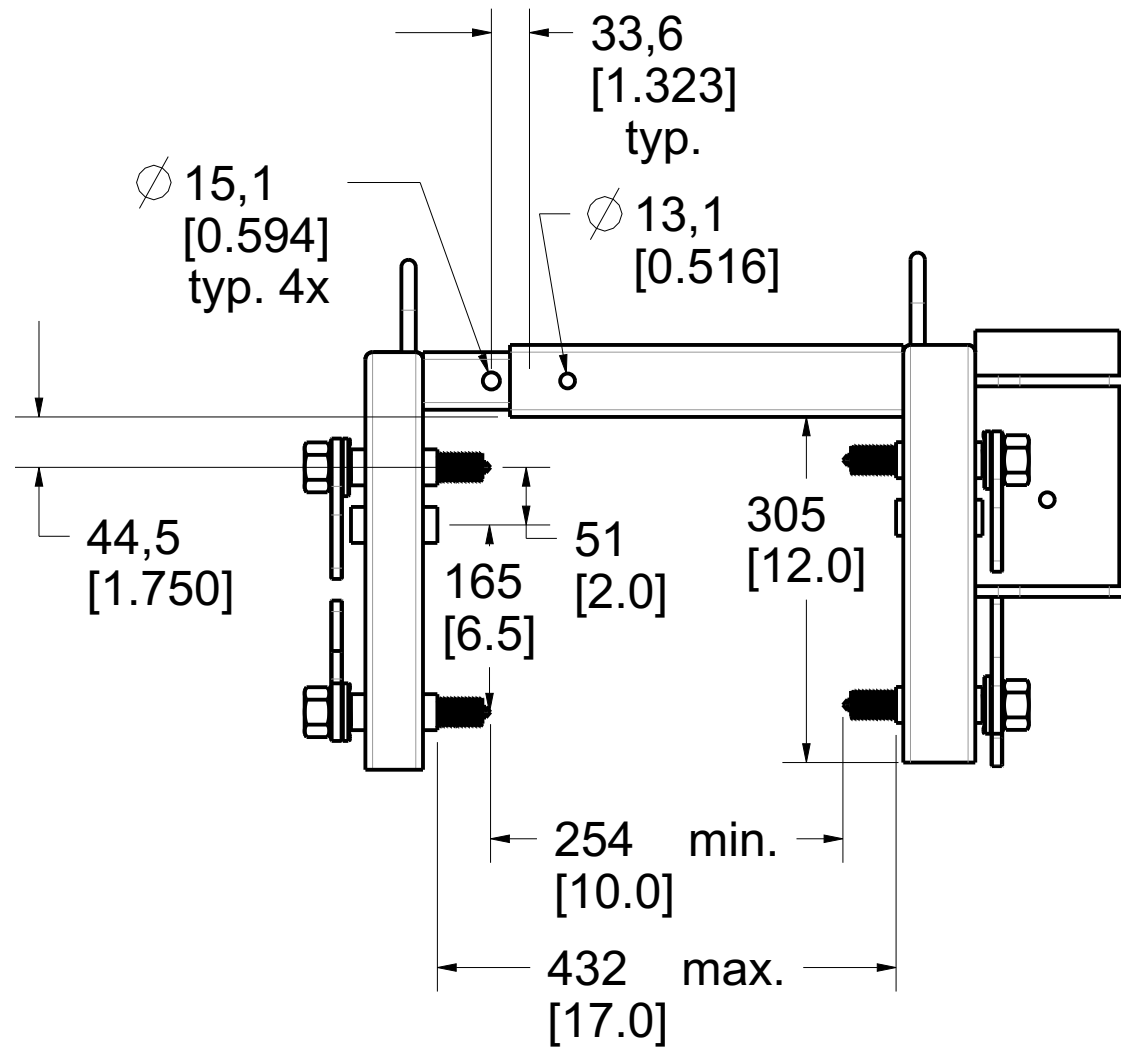

PAT.NO.:

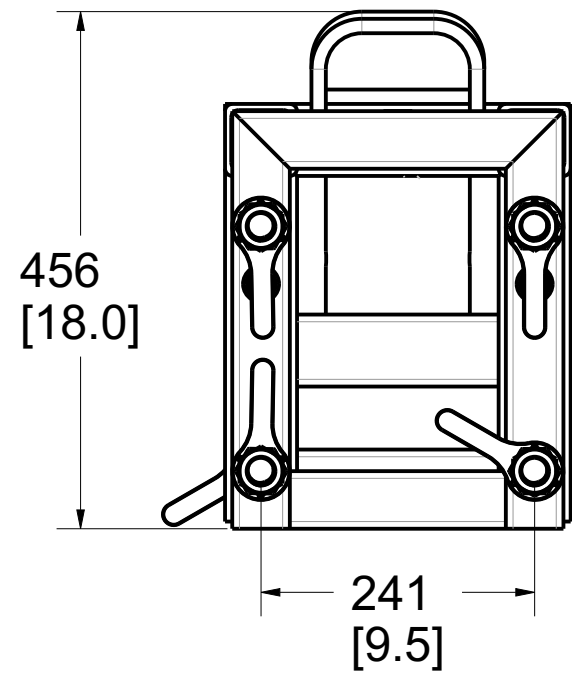
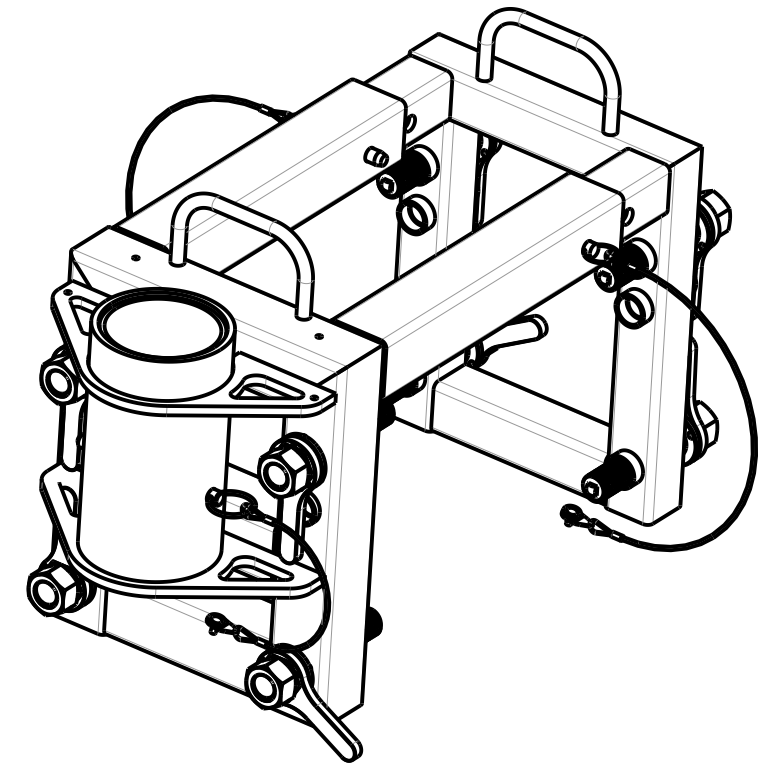
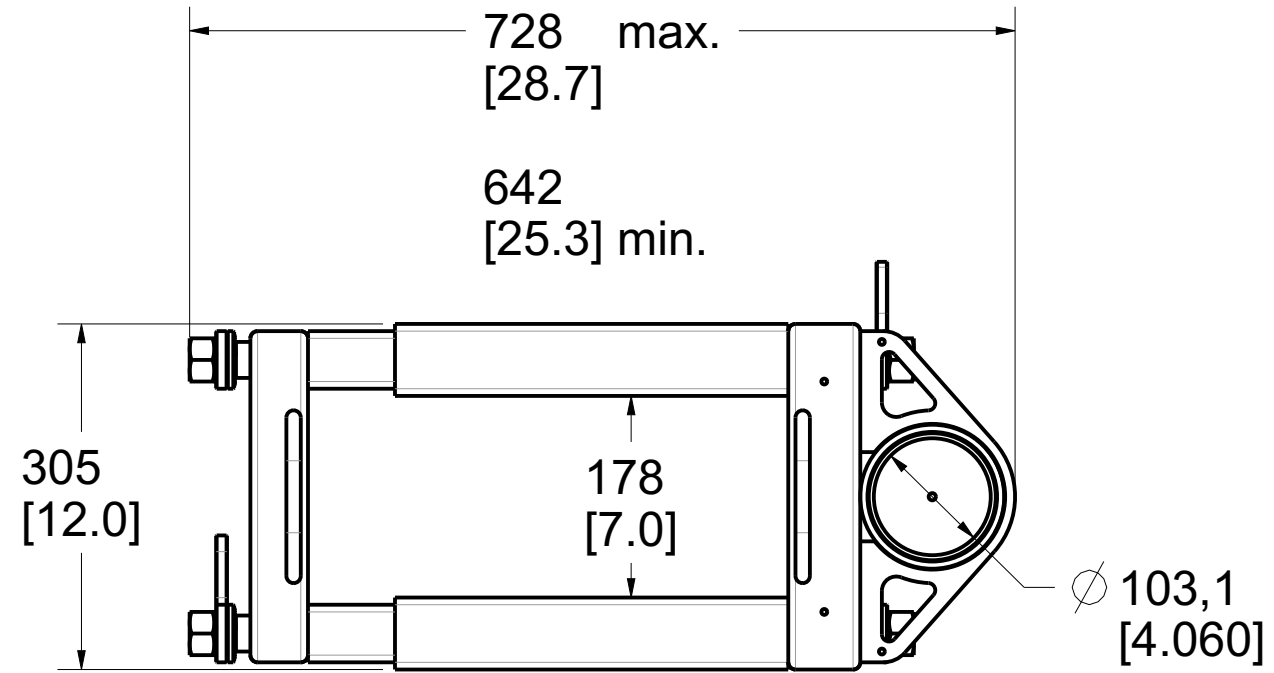

**PRODUITS DE SERVICE PUBLICS INNOVA INC.**  
**INNOVA PUBLIC UTILITY PRODUCTS INC.**

© 9105-0732 QUEBEC INC. and under exclusive license to INNOVA PUBLIC UTILITY PRODUCTS INC., (hereafter « INNOVA »). All rights reserved. Protected under the Copyright Act of Canada and international treaties and agreements regarding copyrights. Violators are subject to prosecution and other legal recourses for infringement. Any reproduction, adaptation or other use or disclosure whatsoever, in totality or in part, and in any form or by any means whatsoever, strictly forbidden and requires the prior written approval of INNOVA. All data is the exclusive property of 9105-0732 QUEBEC INC. and under exclusive license to INNOVA and cannot be used nor disclosed in any way either without the prior written approval of INNOVA.

<b>WEIGHT:</b>	<b>TITLE:</b>			
106.5 Lb	102mm (4'') Adjustable Wall Adapter			
48.3 Kg	254mm à 432mm (10''-17'')			

<b>COLOR:</b>	<b>Material:</b>	<b>SHEET(S):</b>	<b>PROJET:</b>	<b>Rev.</b>
Zinc plated	Steel	1 / 4	IN-2380	03

Product number: **IN-2380**

**Recommendations:**

Concrete must be made of 0,2% gross area rebar reinforced 13.8 MPa (2000psi) or better  
 Minimum thickness of 254mm (10")  
 OR  
 Non reinforced Concrete  
 13.8 MPa (2000psi) or better.  
 Minimum thickness of 286mm (11 1/4")

**Moment capacity:**  
 19,524 N•m (172 800 lbf•in)  
**Vertical load:** 22,241 N (5 000 lbf).  
 N.B. It is the responsibility of the field engineer to assure installation compliance.

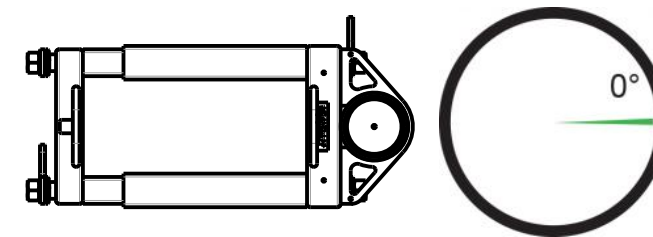
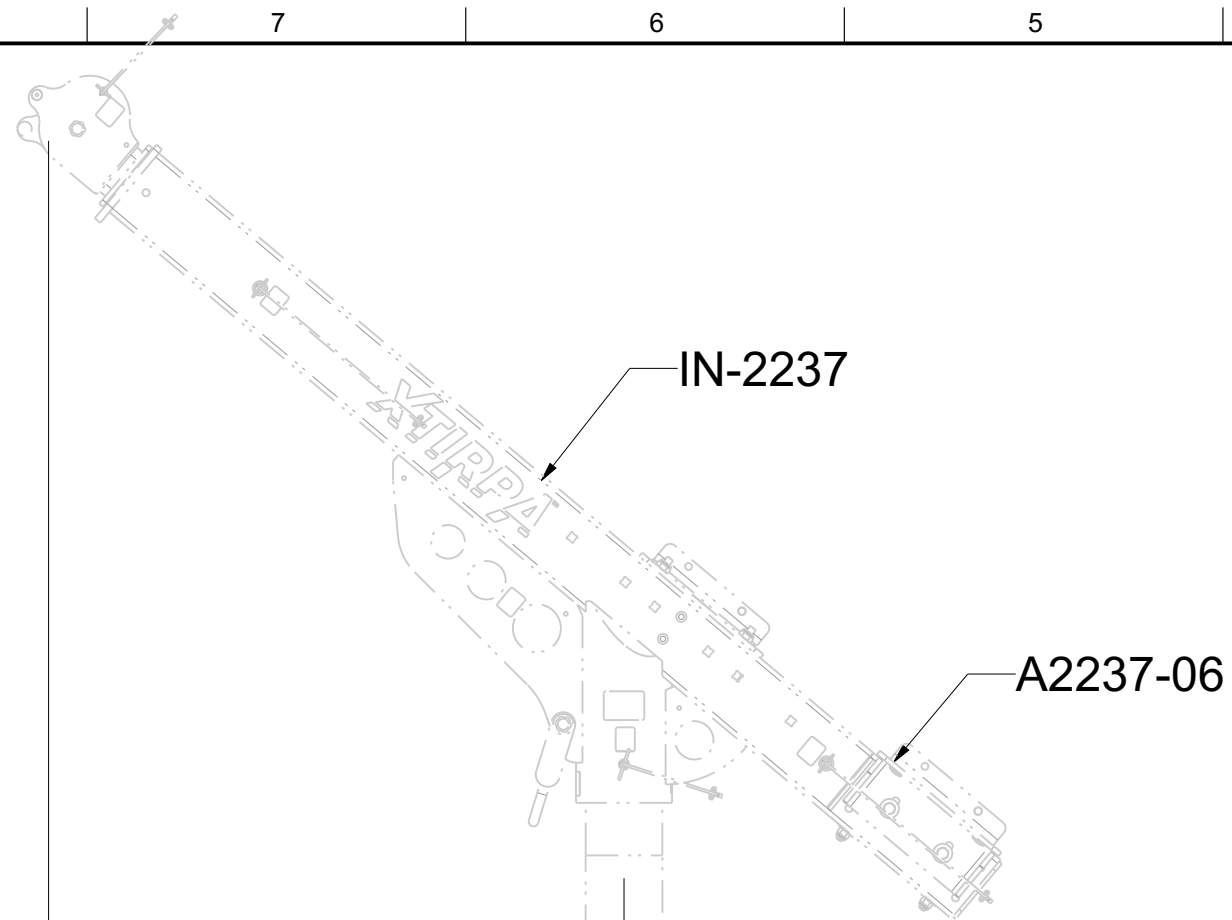

**Permissible Working Angle**

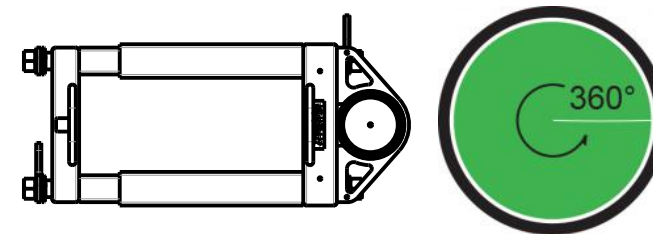

**Permissible Angle of Recuperation**

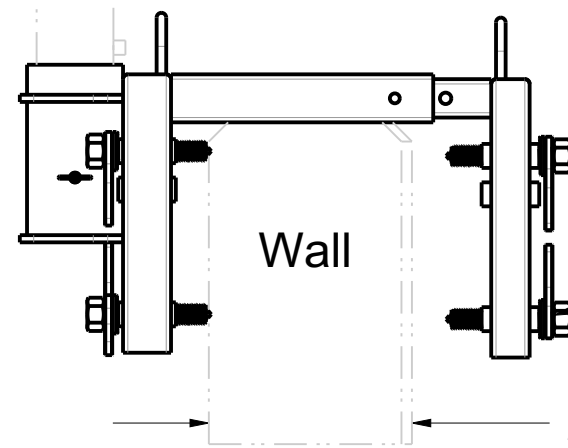

**Torque Value (8x)**  
 34-41 N•m (25-30 lbf•ft)

PAT.NO.:				
PRODUITS DE SERVICE PUBLICS INNOVA INC. INNOVA PUBLIC UTILITY PRODUCTS INC.				
<small>© 9105-0732 QUEBEC INC. and under exclusive license to INNOVA PUBLIC UTILITY PRODUCTS INC., (hereafter « INNOVA »). All rights reserved. Protected under the Copyright Act of Canada and international treaties and agreements regarding copyrights. Violators are subject to prosecution and other legal recourses for infringement. Any reproduction, adaptation or other use or disclosure whatsoever, in totality or in part, and in any form or by any means whatsoever, strictly forbidden and requires the prior written approval of INNOVA. All data is the exclusive property of 9105-0732 QUEBEC INC. and under exclusive license to INNOVA and cannot be used nor disclosed in any way either without the prior written approval of INNOVA.</small>				
WEIGHT:	TITLE:			
106.5 Lb	102mm (4") Adjustable Wall Adapter			
48.3 Kg	254mm à 432mm (10"-17")			
COLOR:	Material:	SHEET(S):	PROJET:	Rev.
Zinc plated	Steel	2 / 4	IN-2380	03

**SPECIFICATIONS**

This equipment is considered as part of a personal fall arrest system (PFAS).

It is only to be used in conjunction with a personal fall arrest system that limits the maximum arrest force (MAF) to 6,0 kN.

Working load limit (WLL) :	164 kg	(360 lb)
Minimum breaking strength :	16,0 kN	(3 600 lbf)
Maximum working moment :	2,0 kN•m	(17 280 lbf•in)
Maximum design moment :	19,5 kN•m	(172 800 lbf•in)

**STANDARDS**

Name	Classification	Year	Users
AS / NZS 5532	Freefall Arrest	2013	1
ANSI Z359.18	D	2017	1
CSA Z259.15	AD	2022	1
OSHA 1910.140			1
OSHA 1926.502			1
EN 795	B	2012	1
TS 16415		2013	3

**MATERIAL AND CONSTRUCTION**

Structure:	Steel
Welding certification:	CSA W47.2M CSA W59 & 47.1
Surface finish:	Zinc Plated

**RESTRICTIONS**

This product is to be used only with products approved by Innova Public Utility Products inc.

**IMPORTANT :**

All adjustment pins shall be used at all times.  
Always use the product perpendicular to the wall. It is not considered as a permanent structure.

\*\*The positioning pins must always be in place when manoeuvring personnel. Otherwise, serious injuries may occur. Periodic inspections of hardware must be done. In the occurrence of a fall or the safety of the equipment is in doubt, equipment must be immediately removed from service and inspected by qualified personnel before reuse.

\*\* This equipment must always be operated in a level position.

Product number: **IN-2380**

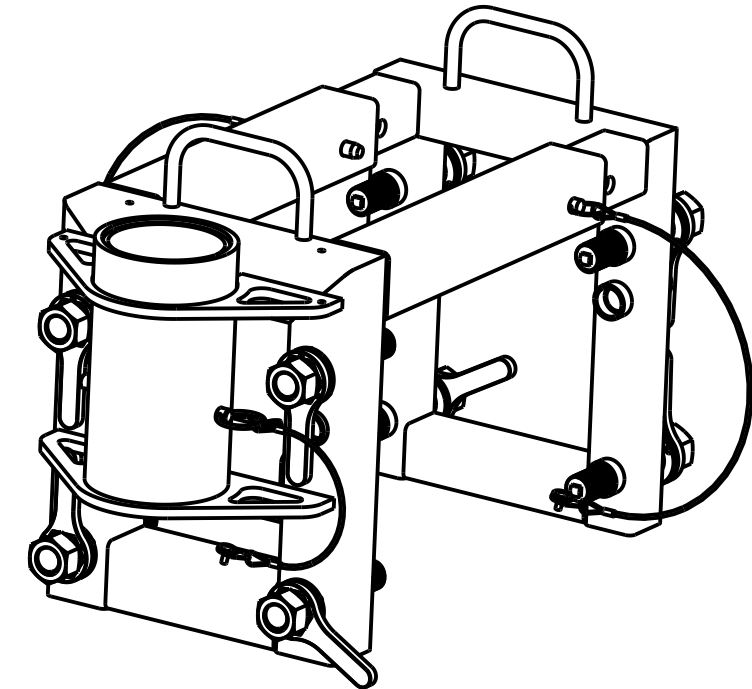

PAT.NO.:				
PRODUITS DE SERVICE PUBLICS INNOVA INC. INNOVA PUBLIC UTILITY PRODUCTS INC.				
<small>© 9105-0732 QUEBEC INC. and under exclusive license to INNOVA PUBLIC UTILITY PRODUCTS INC., (hereafter « INNOVA »). All rights reserved. Protected under the Copyright Act of Canada and international treaties and agreements regarding copyrights. Violators are subject to prosecution and other legal recourses for infringement. Any reproduction, adaptation or other use or disclosure whatsoever, in totality or in part, and in any form or by any means whatsoever, strictly forbidden and requires the prior written approval of INNOVA. All data is the exclusive property of 9105-0732 QUEBEC INC. and under exclusive license to INNOVA and cannot be used nor disclosed in any way either without the prior written approval of INNOVA».</small>				
WEIGHT:	TITLE:			
106.5 Lb	102mm (4") Adjustable Wall Adapter			
48.3 Kg	254mm à 432mm (10"-17")			
COLOR:	Material:	SHEET(S):	PROJET:	Rev.
Zinc plated	Steel	3 / 4	IN-2380	03

Product number: **IN-2380**

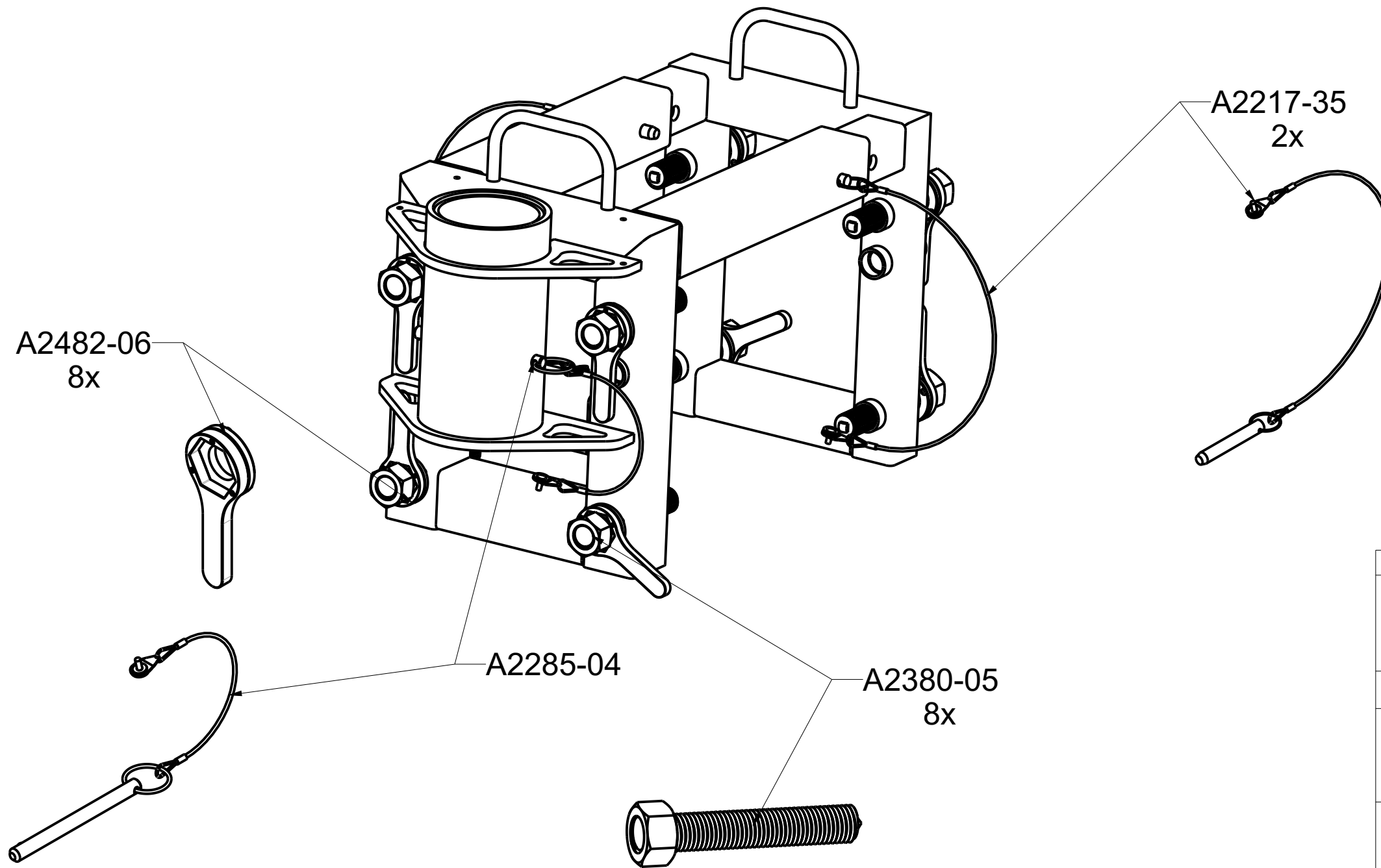

PAT.NO.:				
<b>PRODUITS DE SERVICE PUBLICS INNOVA INC.</b> <b>INNOVA PUBLIC UTILITY PRODUCTS INC.</b>				
© 9105-0732 QUEBEC INC. and under exclusive license to INNOVA PUBLIC UTILITY PRODUCTS INC., (hereafter « INNOVA »). All rights reserved. Protected under the Copyright Act of Canada and international treaties and agreements regarding copyrights. Violators are subject to prosecution and other legal recourses for infringement. Any reproduction, adaptation or other use or disclosure whatsoever, in totality or in part, and in any form or by any means whatsoever, strictly forbidden and requires the prior written approval of INNOVA. All data is the exclusive property of 9105-0732 QUEBEC INC. and under exclusive license to INNOVA and cannot be used nor disclosed in any way either without the prior written approval of INNOVA®.				
WEIGHT:	TITLE:			
106.5 Lb	102mm (4'') Adjustable Wall Adapter			
48.3 Kg	254mm à 432mm (10''-17'')			
COLOR:	Material:	SHEET(S):	PROJET:	Rev.
Zinc plated	Steel	4 / 4	IN-2380	03