

INNOVA PUBLIC UTILITY PRODUCTS INC.				
TITLE:  TRIPOD 9FT (2743mm) WITH BRACKET FOR WINCH & SRL				
WEIGHT :		DRAWN BY:		VERIFIED BY:
(kg)	(lb)	P. Petit		
29.0	63.9	DATE: 03/04/2019		
SURFACE FINISH:		SCALE: 3:100		
MATERIAL: ALUMINUM		SHEET(S): 1 / 4	FORMAT: A	No. DRAWING: DA2429-01 ANG 02
<small>© 9105-0732 QUEBEC INC., under exclusive license to PRODUCTS DE SERVICES PUBLICS INNOVA INC., (hereinafter "INNOVA"). All rights reserved. Protected by the Copyright Act in Canada and international treaties and conventions relating to copyright. Violators are subject to criminal prosecution and other legal remedies for infringement. Any reproduction, adaptation or other use or disclosure of any kind, in whole or in part, and in any form or by any means whatsoever either, is strictly prohibited and requires the prior written consent of INNOVA. The data is the exclusive property of 9105-0732 QUEBEC INC., under exclusive license to INNOVA and cannot be used or disclosed in any way without the prior written consent of INNOVA.</small>				

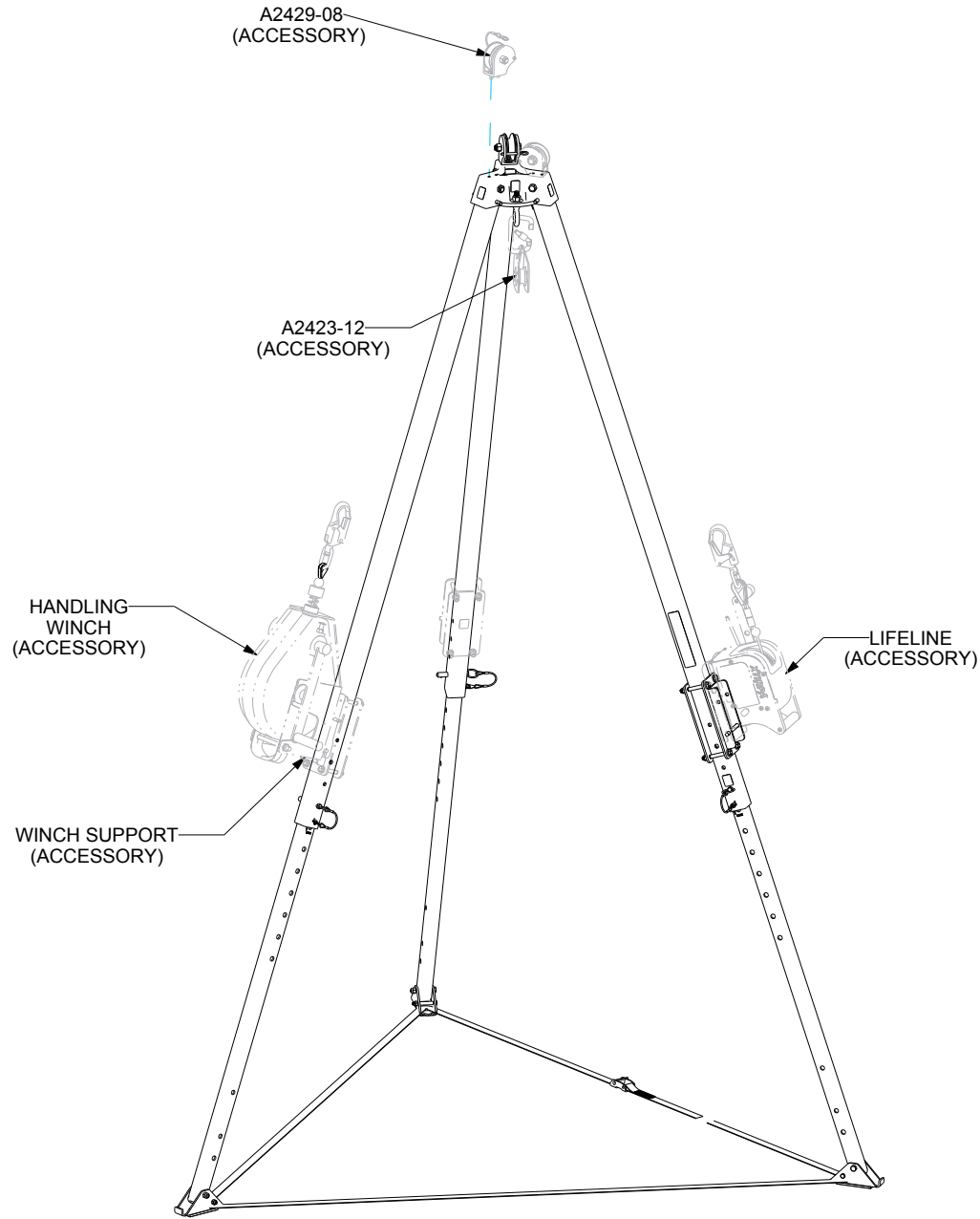

<b>INNOVA PUBLIC UTILITY PRODUCTS INC.</b>				
TITLE:				
<b>TRIPOD 9FT (2743mm) WITH BRACKET FOR WINCH &amp; SRL</b>				
WEIGHT :		DRAWN BY:		VERIFIED:
(kg)	(lb)	P.Petit		
29.0	63.9	DATE:		
		03/04/2019		
SURFACE FINISH:		SCALE:		
		1:50		
MATERIAL:		SHEET(S):	FORMAT:	No. DRAWING:
ALUMINUM		2 / 4	A	DA2429-01_ANG_02
<small>© 9105-0732 QUEBEC INC., under exclusive license to PRODUCTS DE SERVICES PUBLICS INNOVA INC., (hereinafter "INNOVA"). All rights reserved. Protected by the Copyright Act in Canada and international treaties and conventions relating to copyright. Violators are subject to criminal prosecution and other legal remedies for infringement. Any reproduction, adaptation or other use or disclosure of any kind, in whole or in part, and in any form or by any means whatsoever either, is strictly prohibited and requires the prior written consent of INNOVA. The data is the exclusive property of 9105-0732 QUEBEC INC., under exclusive license to INNOVA and cannot be used or disclosed in any way without the prior written consent of INNOVA.</small>				

# SPECIFICATIONS

THIS EQUIPMENT IS CONSIDERED AS PART OF A PERSONAL FALL ARREST SYSTEM (PFAS).

IT IS ONLY TO BE USED IN CONJUNCTION WITH A PERSONAL FALL ARREST SYSTEM THAT LIMITS THE MAXIMUM ARREST FORCE (MAF) TO 8,0 kN.

WORKING LOAD LIMIT (WLL) :	164 kg (360 lb)
MINIMUM BREAKING STRENGTH FOR ANCHORAGE 1 (F1) :	16,0 kN (3 600 lbf)
MINIMUM BREAKING STRENGTH FOR ANCHORAGE 2 (F2) :	16,0 kN (3 600 lbf)
MINIMUM BREAKING STRENGTH FOR ANCHORAGE 3 (F3) :	16,0 kN (3 600 lbf)
MINIMUM BREAKING STRENGTH FOR ANCHORAGE 4 (F4) :	22,2 kN (5 000 lbf)

# STANDARDS

NAME	CLASSIFICATION	YEAR	USERS
ANSI Z359.18	Type D	2017	1
AS/NZS 5532	Freefall	2013	1
CSA Z259.15	Class AD	2022	1
OSHA 1910.140			1
OSHA 1926.502			1
EN 795 / TS 16415	Type B	2012 / 2013	3

# MATERIAL AND CONSTRUCTION

<u>WELDING CERTIFICATION :</u>	<u>STRUCTURE :</u>	<u>HARDWARE :</u>
STEEL / STAINLESS STEEL CSA W59.18 / CSA W47.1 / AWS D 1.6	ALUMINUM	STAINLESS STEEL
ALUMINUM CSA W59.2 / CSA W47.2		

# RESTRICTIONS

THIS EQUIPMENT SHOULD ONLY BE USED WITH PRODUCTS APPROVED BY INNOVA PUBLIC UTILITY PRODUCTS Inc.

THIS EQUIPMENT SHOULD ALWAYS BE USED ON A LEVELED SURFACE.

MAKE SURE ALL HARDWARE AND CONNECTION PINS ARE PROPERLY INSTALLED BEFORE USE.

IN CASE OF FALL OR EQUIPMENT SAFETY IF IN DOUBT, THE EQUIPMENT SHOULD BE REMOVED FROM THE EQUIPMENT IMMEDIATELY. SERVICED AND INSPECTED BY A QUALIFIED PERSON BEFORE REUSE.

PRODUCT NUMBER: IN-2429

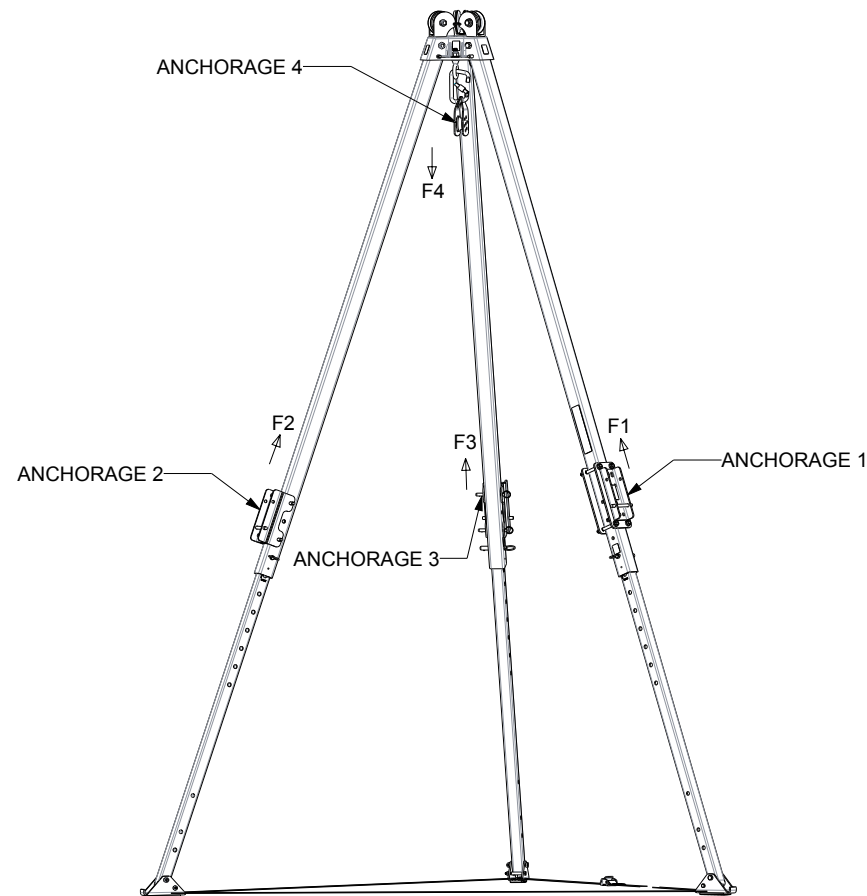

INNOVA PUBLIC UTILITY PRODUCTS INC.				
TITLE:				
TRIPOD 9FT (2743mm) WITH BRACKET FOR WINCH & SRL				
WEIGHT :		DRAWN BY:		VERIFIED BY:
(kg)	(lb)	P.Petit		
29.0	63.9	DATE:		
		03/04/2019		
SURFACE FINISH:		SCALE:		
		1:50		
MATERIAL:		SHEET(S):	FORMAT:	No. DRAWING:
ALUMINUM		3 / 4	A	DA2429-01 ANG 02
<small>© 9105-0732 QUEBEC INC., under exclusive license to PRODUCTS DE SERVICES PUBLICS INNOVA INC., (hereinafter "INNOVA"). All rights reserved. Protected by the Copyright Act in Canada and international treaties and conventions relating to copyright. Violators are subject to criminal prosecution and other legal remedies for infringement. Any reproduction, adaptation or other use or disclosure of any kind, in whole or in part, and in any form or by any means whatsoever either, is strictly prohibited and requires the prior written consent of INNOVA. The data is the exclusive property of 9105-0732 QUEBEC INC., under exclusive license to INNOVA and cannot be used or disclosed in any way without the prior written consent of INNOVA.</small>				

PRODUCT NUMBER: IN-2429

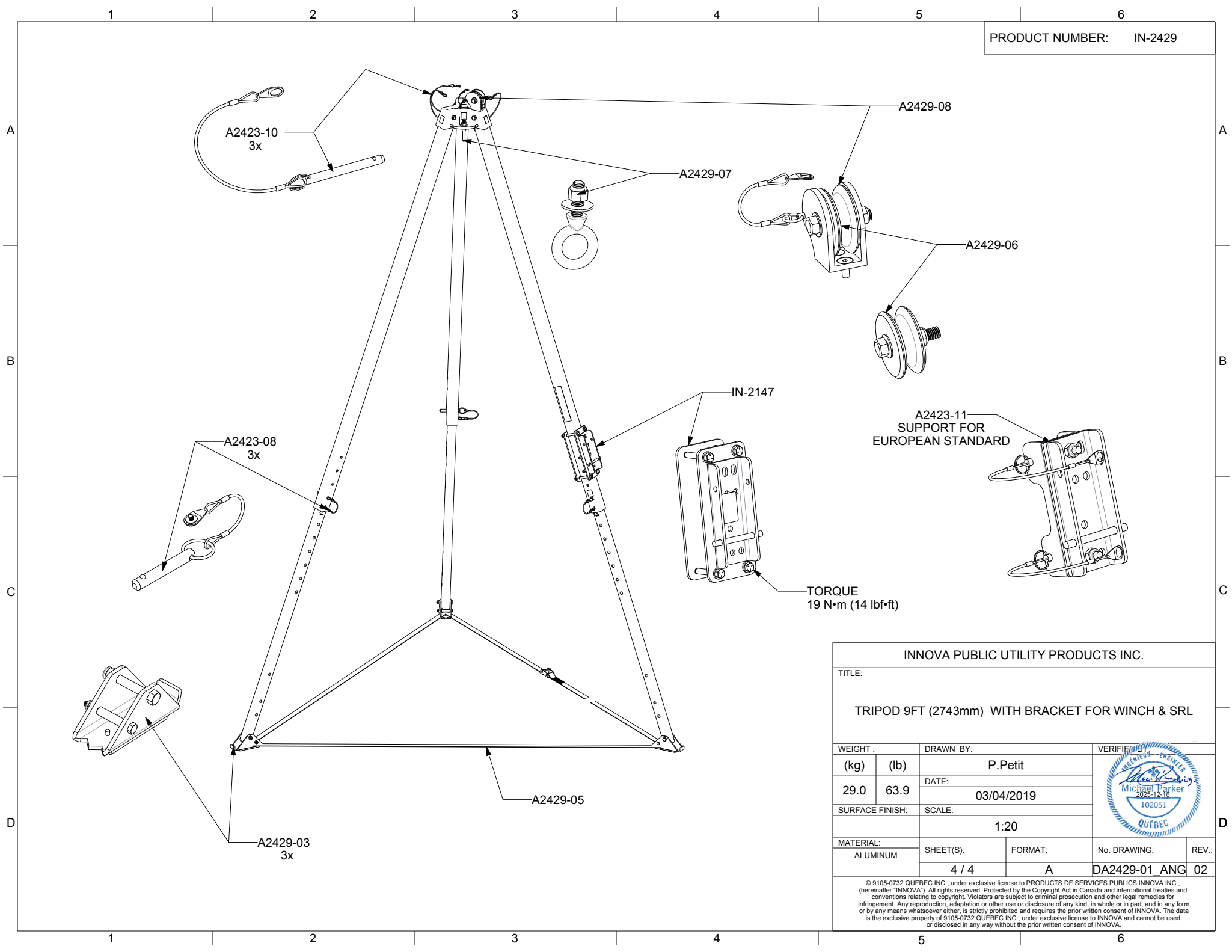

INNOVA PUBLIC UTILITY PRODUCTS INC.				
TITLE:				
TRIPOD 9FT (2743mm) WITH BRACKET FOR WINCH & SRL				
WEIGHT :		DRAWN BY:		VERIFIED BY:
(kg)	(lb)	P. Petit		
29.0	63.9	DATE:		
		03/04/2019		
SURFACE FINISH:		SCALE:		
		1:20		
MATERIAL:		SHEET(S):		FORMAT:
ALUMINUM		4 / 4		A
		No. DRAWING:	REV.:	
		DA2429-01	ANG 02	
<small>© 9105-0732 QUEBEC INC., under exclusive license to PRODUCTS DE SERVICES PUBLICS INNOVA INC., (hereinafter "INNOVA"). All rights reserved. Protected by the Copyright Act in Canada and international treaties and conventions relating to copyright. Violators are subject to criminal prosecution and other legal remedies for infringement. Any reproduction, adaptation or other use or disclosure of any kind, in whole or in part, and in any form or by any means whatsoever either, is strictly prohibited and requires the prior written consent of INNOVA. The data is the exclusive property of 9105-0732 QUEBEC INC., under exclusive license to INNOVA and cannot be used or disclosed in any way without the prior written consent of INNOVA.</small>				