

Manhole Diameter
Acceptable Tolerance
762 [30,0] min.
813 [32,0] max.

PAT.NO.:	

PRODUITS DE SERVICE PUBLICS INNOVA INC.
INNOVA PUBLIC UTILITY PRODUCTS INC.

© 9105-0732 QUEBEC INC. and under exclusive license to INNOVA PUBLIC UTILITY PRODUCTS INC., (hereafter « INNOVA »). All rights reserved. Protected under the Copyright Act of Canada and international treaties and agreements regarding copyrights. Violators are subject to prosecution and other legal recourses for infringement. Any reproduction, adaptation or other use or disclosure whatsoever, in totality or in part, and in any form or by any means whatsoever, strictly forbidden and requires the prior written approval of INNOVA. All data is the exclusive property of 9105-0732 QUEBEC INC. and under exclusive license to INNOVA and cannot be used nor disclosed in any way either without the prior written approval of INNOVA.

WEIGHT:	TITLE:			
60.0 Lb	762mm (30") Manhole Collar 0-30 Degree			
27.2 Kg				
COLOR:	Material:	SHEET(S):	PROJET:	Rev.
Yellow XTIRPA	Aluminum	1 / 4	IN-2487	02

Product number: **IN-2487**

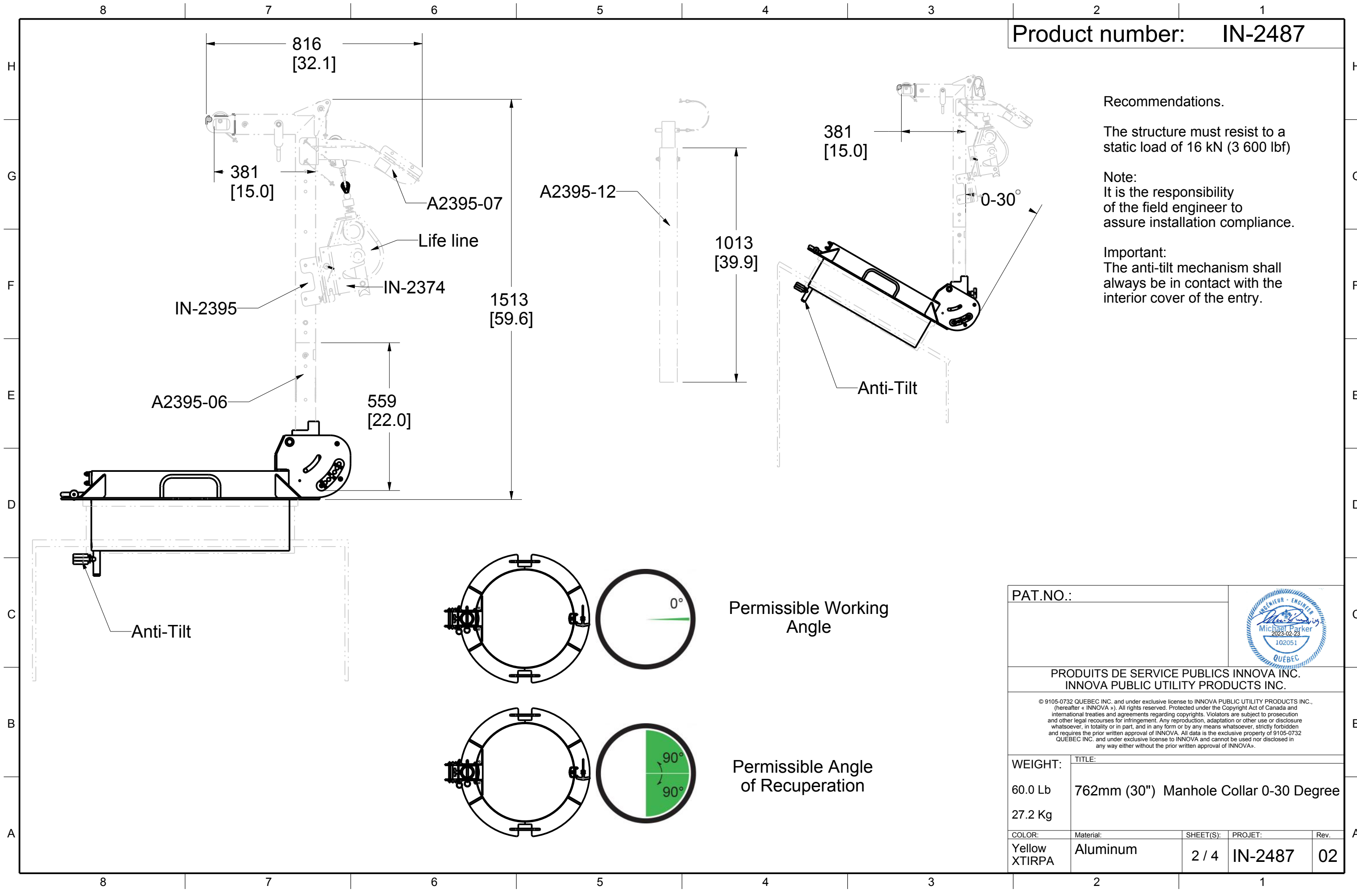

Recommendations.
 The structure must resist to a static load of 16 kN (3 600 lbf)

Note:
 It is the responsibility of the field engineer to assure installation compliance.

Important:
 The anti-tilt mechanism shall always be in contact with the interior cover of the entry.

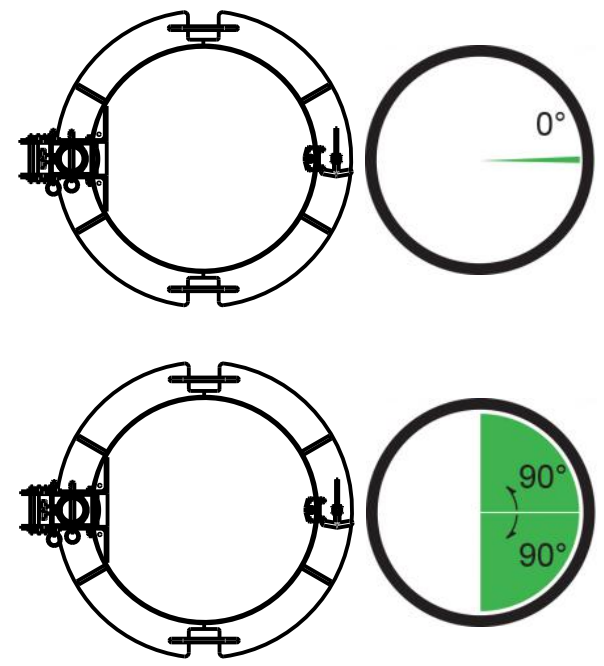

Permissible Working Angle

Permissible Angle of Recuperation

PAT.NO.:				
PRODUITS DE SERVICE PUBLICS INNOVA INC. INNOVA PUBLIC UTILITY PRODUCTS INC.				
© 9105-0732 QUEBEC INC. and under exclusive license to INNOVA PUBLIC UTILITY PRODUCTS INC., (hereafter « INNOVA »). All rights reserved. Protected under the Copyright Act of Canada and international treaties and agreements regarding copyrights. Violators are subject to prosecution and other legal recourses for infringement. Any reproduction, adaptation or other use or disclosure whatsoever, in totality or in part, and in any form or by any means whatsoever, strictly forbidden and requires the prior written approval of INNOVA. All data is the exclusive property of 9105-0732 QUEBEC INC. and under exclusive license to INNOVA and cannot be used nor disclosed in any way either without the prior written approval of INNOVA.				
WEIGHT:	TITLE:			
60.0 Lb	762mm (30") Manhole Collar 0-30 Degree			
27.2 Kg				
COLOR:	Material:	SHEET(S):	PROJET:	Rev.
Yellow XTIRPA	Aluminum	2 / 4	IN-2487	02

SPECIFICATIONS

This equipment is considered as part of a personal fall arrest system (PFAS).

It is only to be used in conjunction with a personal fall arrest system that limits the maximum arrest force (MAF) to 6,0 kN.

Working load limit (WLL) :	164 kg	(360 lb)
Minimum breaking strength :	16,0 kN	(3 600 lbf)
Maximum working moment :	0,732 kN•m	(6 480 lbf•in)
Maximum design moment :	7,320 kN•m	(64 800 lbf•in)

STANDARDS

Name	Classification	Year	Users
ANSI Z359.1 (R1999)		2007	1
CSA Z259.2.1		1998	1
OSHA 1910.66	App C		1
EN 795	B	2012	1
TS 16415		2013	2

MATERIAL AND CONSTRUCTION

Structure :	Aluminum 6061-T6
Hardware :	Stainless Steel
Welding certification :	Aluminum : CSA W47,2M

RESTRICTIONS

This equipment is to be used only with products approved by Innova Public Utility Products Inc.

This equipment must always be operated on a level surface.

Ensure that all hardware and connecting pins are properly installed before use.

In the occurrence of a fall or that the safety of the equipment is in doubt, the equipment must be immediately removed from service and inspected by qualified personnel before reuse.

Product number: **IN-2487**

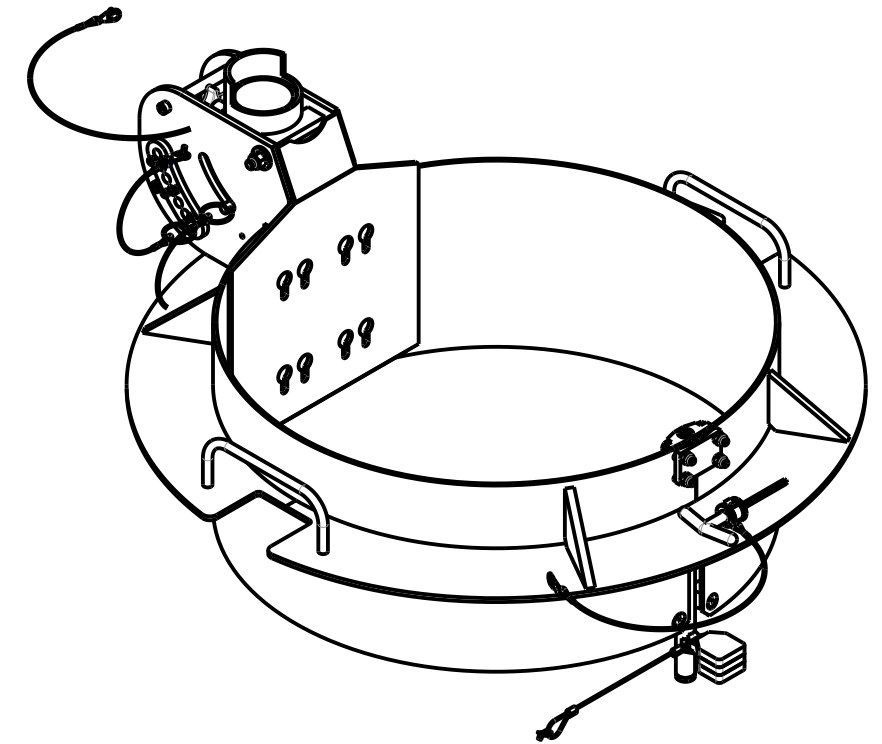

Also Available Clear Anodized

PAT.NO.:				
PRODUITS DE SERVICE PUBLICS INNOVA INC. INNOVA PUBLIC UTILITY PRODUCTS INC.				
© 9105-0732 QUEBEC INC. and under exclusive license to INNOVA PUBLIC UTILITY PRODUCTS INC., (hereafter « INNOVA »). All rights reserved. Protected under the Copyright Act of Canada and international treaties and agreements regarding copyrights. Violators are subject to prosecution and other legal recourses for infringement. Any reproduction, adaptation or other use or disclosure whatsoever, in totality or in part, and in any form or by any means whatsoever, strictly forbidden and requires the prior written approval of INNOVA. All data is the exclusive property of 9105-0732 QUEBEC INC. and under exclusive license to INNOVA and cannot be used nor disclosed in any way either without the prior written approval of INNOVA®.				
WEIGHT:	TITLE:			
60.0 Lb	762mm (30") Manhole Collar 0-30 Degree			
27.2 Kg				
COLOR:	Material:	SHEET(S):	PROJET:	Rev.
Yellow XTIRPA	Aluminum	3 / 4	IN-2487	02

Product number: IN-2487

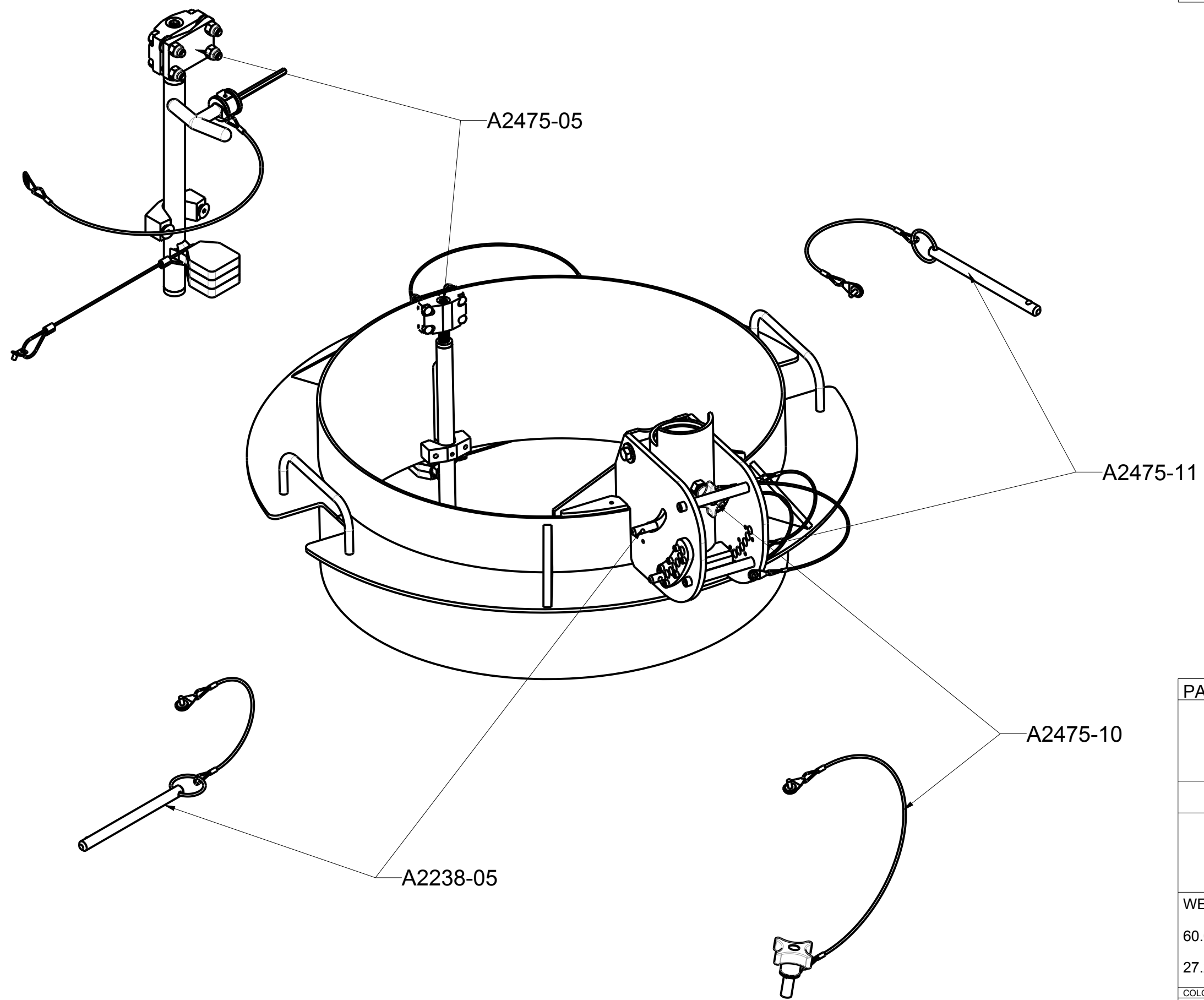

PAT.NO.:				
PRODUITS DE SERVICE PUBLICS INNOVA INC. INNOVA PUBLIC UTILITY PRODUCTS INC.				
<small>© 9105-0732 QUEBEC INC. and under exclusive license to INNOVA PUBLIC UTILITY PRODUCTS INC., (hereafter « INNOVA »). All rights reserved. Protected under the Copyright Act of Canada and international treaties and agreements regarding copyrights. Violators are subject to prosecution and other legal recourses for infringement. Any reproduction, adaptation or other use or disclosure whatsoever, in totality or in part, and in any form or by any means whatsoever, strictly forbidden and requires the prior written approval of INNOVA. All data is the exclusive property of 9105-0732 QUEBEC INC. and under exclusive license to INNOVA and cannot be used nor disclosed in any way either without the prior written approval of INNOVA».</small>				
WEIGHT:	TITLE:			
60.0 Lb	762mm (30") Manhole Collar 0-30 Degree			
27.2 Kg				
COLOR:	Material:	SHEET(S):	PROJET:	Rev.
Yellow XTIRPA	Aluminum	4 / 4	IN-2487	02