

SEE DETAIL A

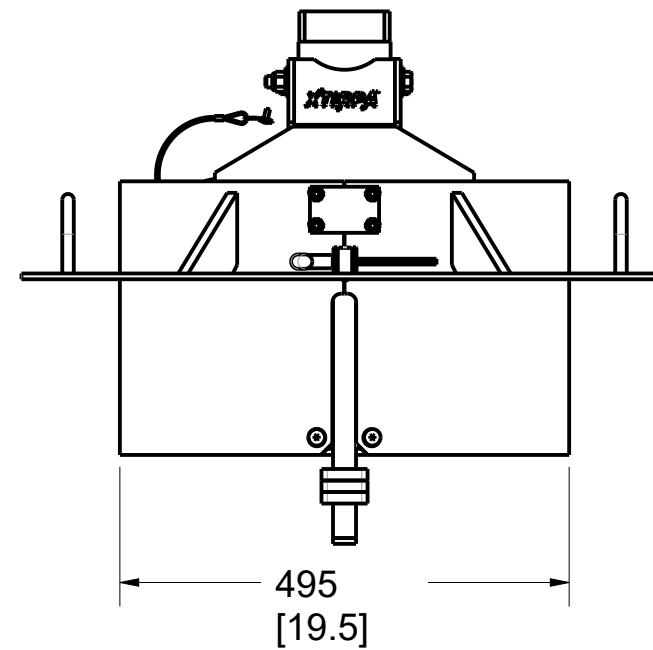
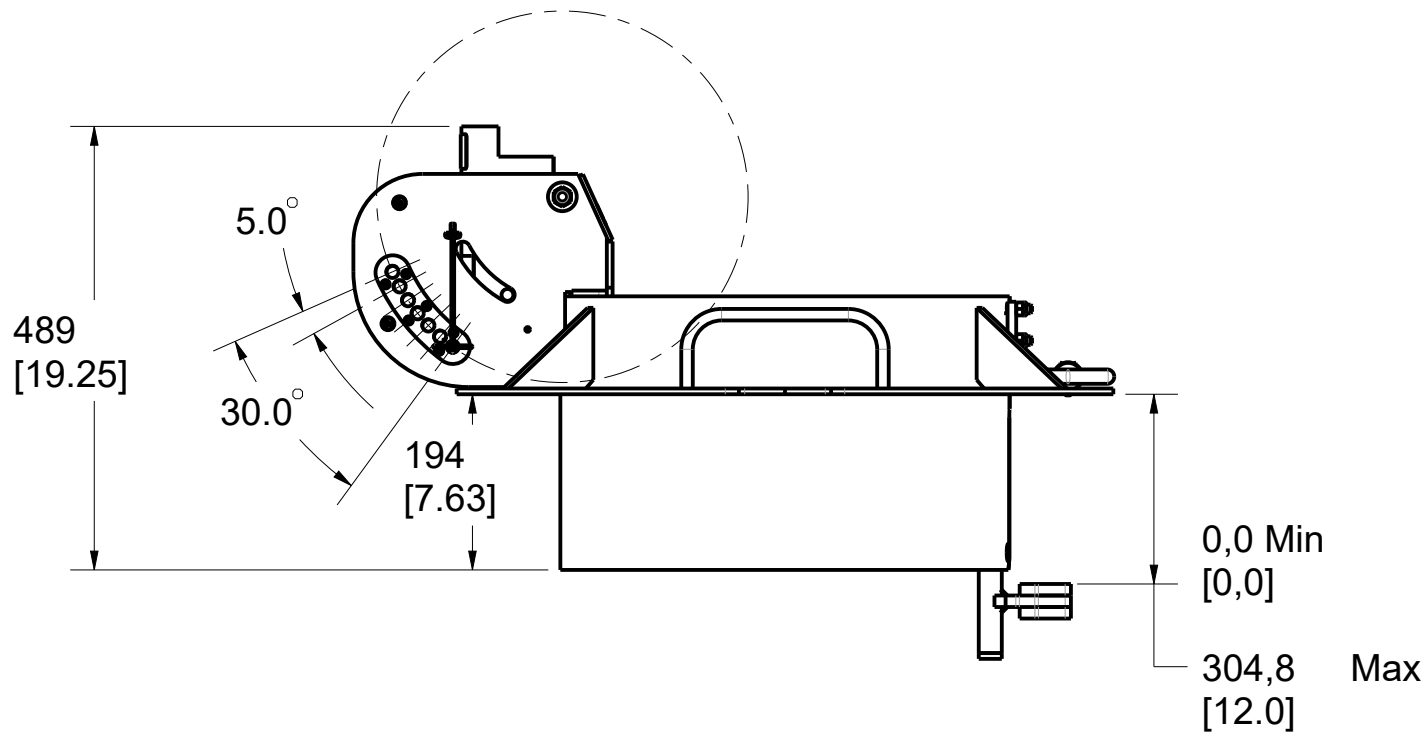
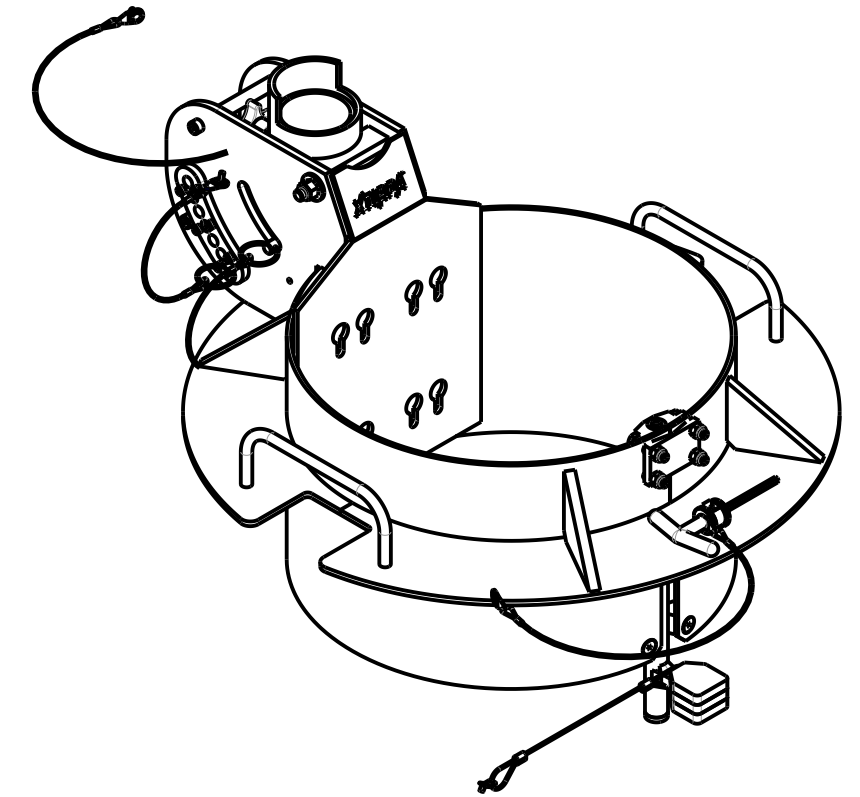
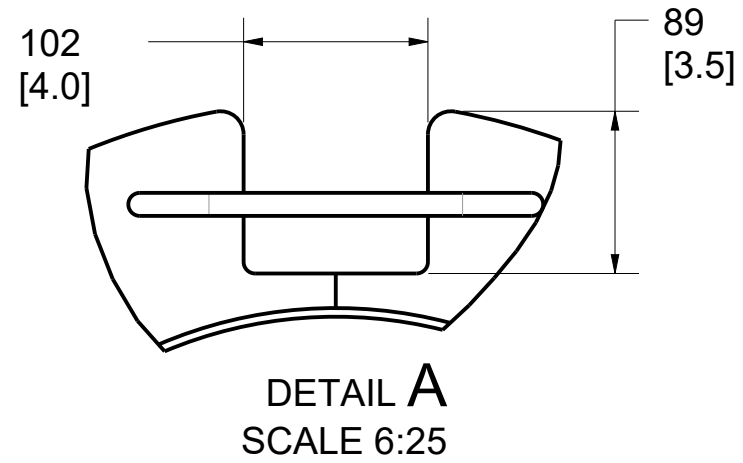
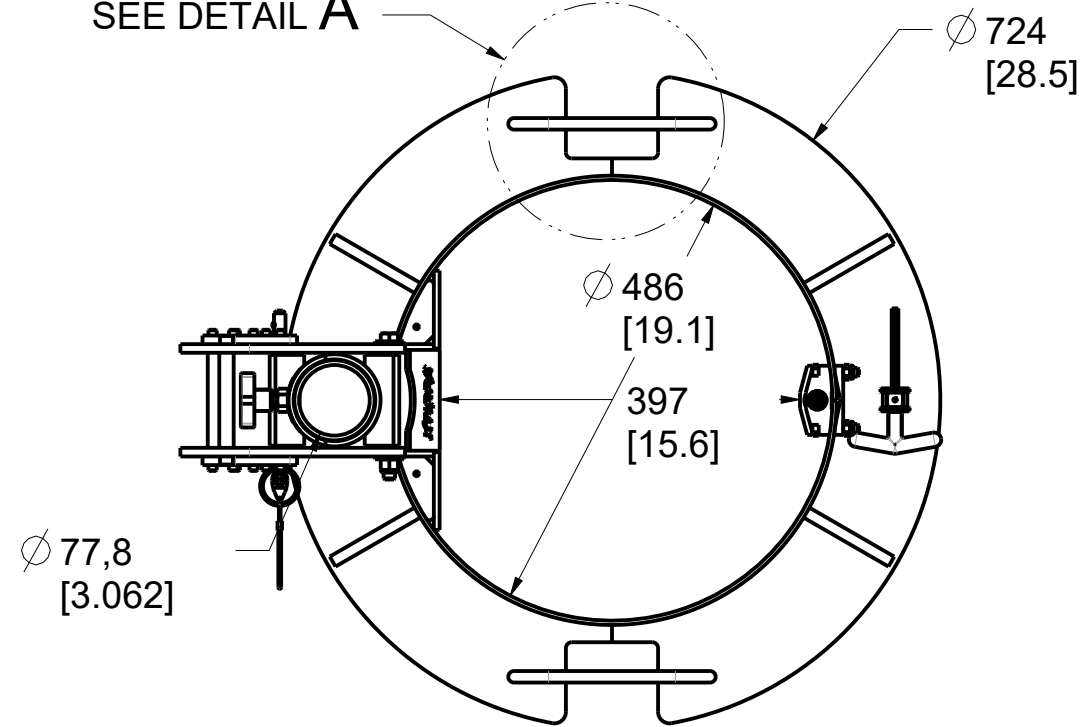

Manhole diameter
acceptable tolerance
508 [20,0] Min
559 [22,0] Max

PAT.NO.:	

PRODUITS DE SERVICE PUBLICS INNOVA INC.
INNOVA PUBLIC UTILITY PRODUCTS INC.

© 9105-0732 QUEBEC INC. and under exclusive license to INNOVA PUBLIC UTILITY PRODUCTS INC., (hereafter « INNOVA »). All rights reserved. Protected under the Copyright Act of Canada and international treaties and agreements regarding copyrights. Violators are subject to prosecution and other legal recourses for infringement. Any reproduction, adaptation or other use or disclosure whatsoever, in totality or in part, and in any form or by any means whatsoever, strictly forbidden and requires the prior written approval of INNOVA. All data is the exclusive property of 9105-0732 QUEBEC INC. and under exclusive license to INNOVA and cannot be used nor disclosed in any way either without the prior written approval of INNOVA.

WEIGHT:	TITLE:			
48 Lb	508mm (20") Manhole collar 0-30 degree			
22 Kg				

COLOR:	Material:	SHEET(S):	PROJET:	Rev.
Safety yellow	Aluminum	1 / 4	IN-2497	01

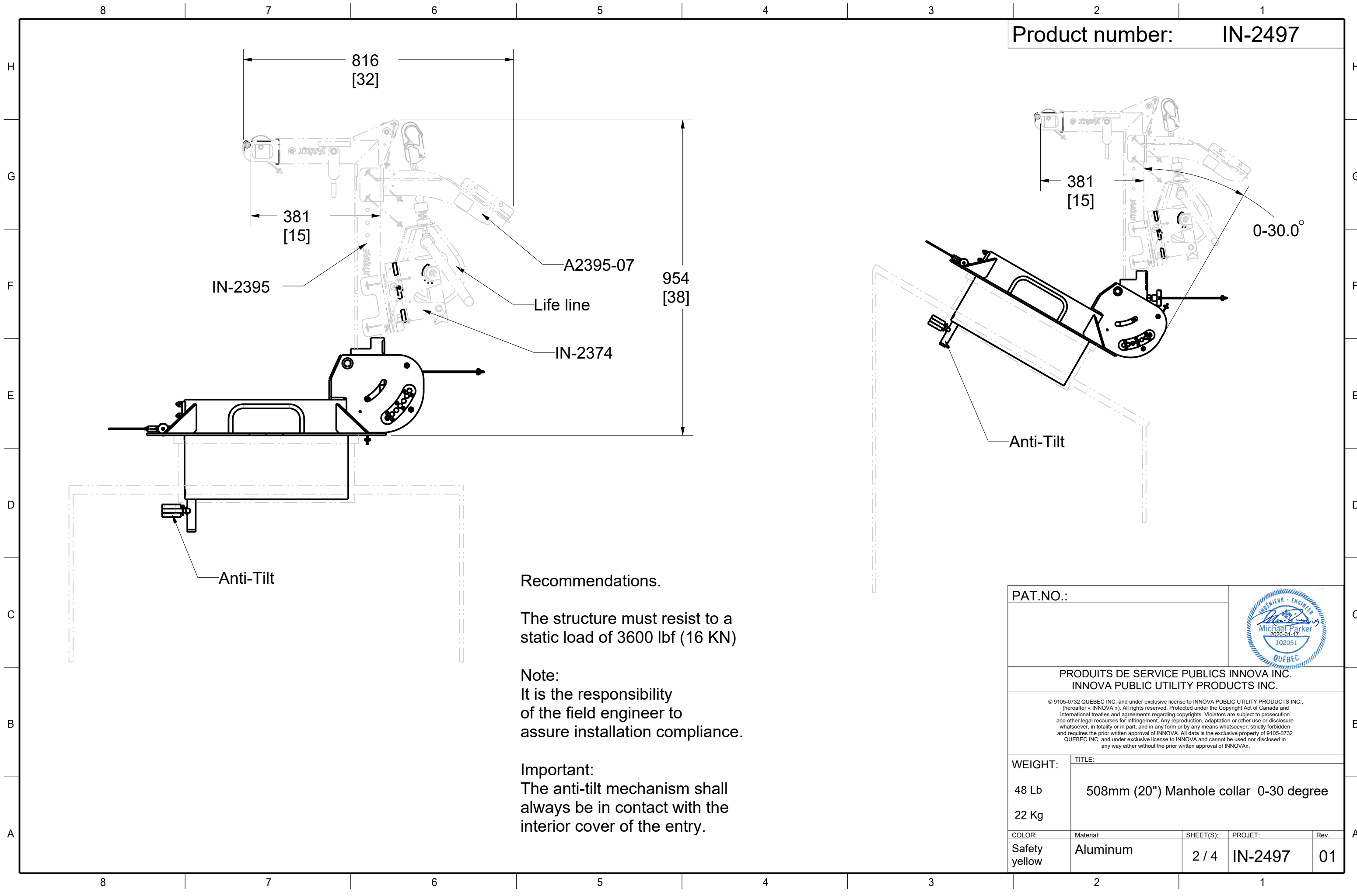

Recommendations.

The structure must resist to a static load of 3600 lbf (16 KN)

Note:
It is the responsibility of the field engineer to assure installation compliance.

Important:
The anti-tilt mechanism shall always be in contact with the interior cover of the entry.

PAT.NO.:				
PRODUITS DE SERVICE PUBLICS INNOVA INC. INNOVA PUBLIC UTILITY PRODUCTS INC.				
© 9105-0732 QUEBEC INC. and under exclusive license to INNOVA PUBLIC UTILITY PRODUCTS INC., (hereafter « INNOVA »). All rights reserved. Protected under the Copyright Act of Canada and international treaties and agreements regarding copyrights. Violators are subject to prosecution and other legal recourses for infringement. Any reproduction, adaptation or other use or disclosure whatsoever, in totality or in part, and in any form or by any means whatsoever, strictly forbidden and requires the prior written approval of INNOVA. All data is the exclusive property of 9105-0732 QUEBEC INC. and under exclusive license to INNOVA and cannot be used nor disclosed in any way either without the prior written approval of INNOVA.				
WEIGHT:	TITLE:			
48 Lb	508mm (20") Manhole collar 0-30 degree			
22 Kg				
COLOR:	Material:	SHEET(S):	PROJET:	Rev.
Safety yellow	Aluminum	2 / 4	IN-2497	01

SPECIFICATIONS

H This equipment is considered as part of a personal fall arrest system (PFAS) with a maximum working capacity of 164 Kg (360 lb).

It is only to be used in conjunction with a personal fall arrest system that limits the maximum arrest force (MAF).

G Working load (mass) and moment:
164 Kg (360 lb)
610 Nm (5,400 lbf-in)

Max Design Capacity
16 KN (3,600 lbf)
6,101 Nm (54,000 lbf-in).

F STANDARDS

Meets the following standards:
OSHA Personal fall arrest system - 1910.66 App C
ANSI Safety requirements for personal fall arrest system, subsystems and components Z359.1 / 2007
E CE EN 795 :2012 Type B
CEN/TS 16415: 2013 (2 Users)

MATERIAL AND CONSTRUCTION

Rings, Handles, reinforcements :Structural Aluminum
Sleeve : Stainless Steel
Sleeve bearing : PVC
D Pin : Stainless steel
Lanyard : Nylon covered stainless steel Cable
Finish :Yellow security powder paint
Welding Certification : CSA W47,2M / CSA W59 & W47.1 & AWS D1.6

C RESTRICTIONS

This product is to be used only with products approved by Innova Public Utility Products inc.

IMPORTANT :
**The positioning pins must always be in place when available.

B Otherwise, serious injuries may occur.
Periodic inspections of hardware must be done.
In the occurrence of a fall or the safety of the equipment is in doubt, equipment must be immediately removed from service and inspected by qualified personnel before reuse.

A ** This equipment must always be operated with the mast in the vertical position.

Product number: IN-2497

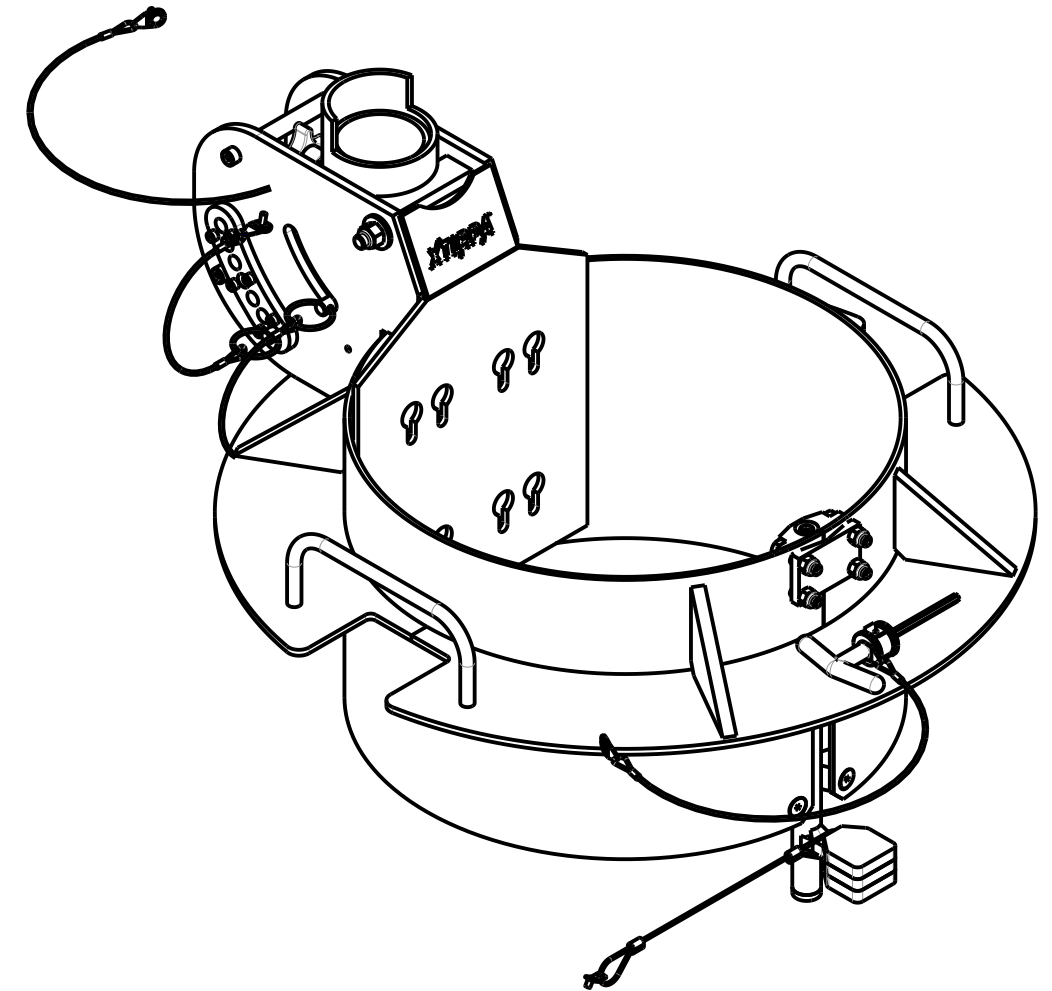

PAT.NO.:				
PRODUITS DE SERVICE PUBLICS INNOVA INC. INNOVA PUBLIC UTILITY PRODUCTS INC.				
© 9105-0732 QUEBEC INC. and under exclusive license to INNOVA PUBLIC UTILITY PRODUCTS INC., (hereafter « INNOVA »). All rights reserved. Protected under the Copyright Act of Canada and international treaties and agreements regarding copyrights. Violators are subject to prosecution and other legal recourses for infringement. Any reproduction, adaptation or other use or disclosure whatsoever, in totality or in part, and in any form or by any means whatsoever, strictly forbidden and requires the prior written approval of INNOVA. All data is the exclusive property of 9105-0732 QUEBEC INC. and under exclusive license to INNOVA and cannot be used nor disclosed in any way either without the prior written approval of INNOVA.				
WEIGHT:	TITLE:			
48 Lb	508mm (20") Manhole collar 0-30 degree			
22 Kg				
COLOR:	Material:	SHEET(S):	PROJET:	Rev.
Safety yellow	Aluminum	3 / 4	IN-2497	01

Product number: IN-2497

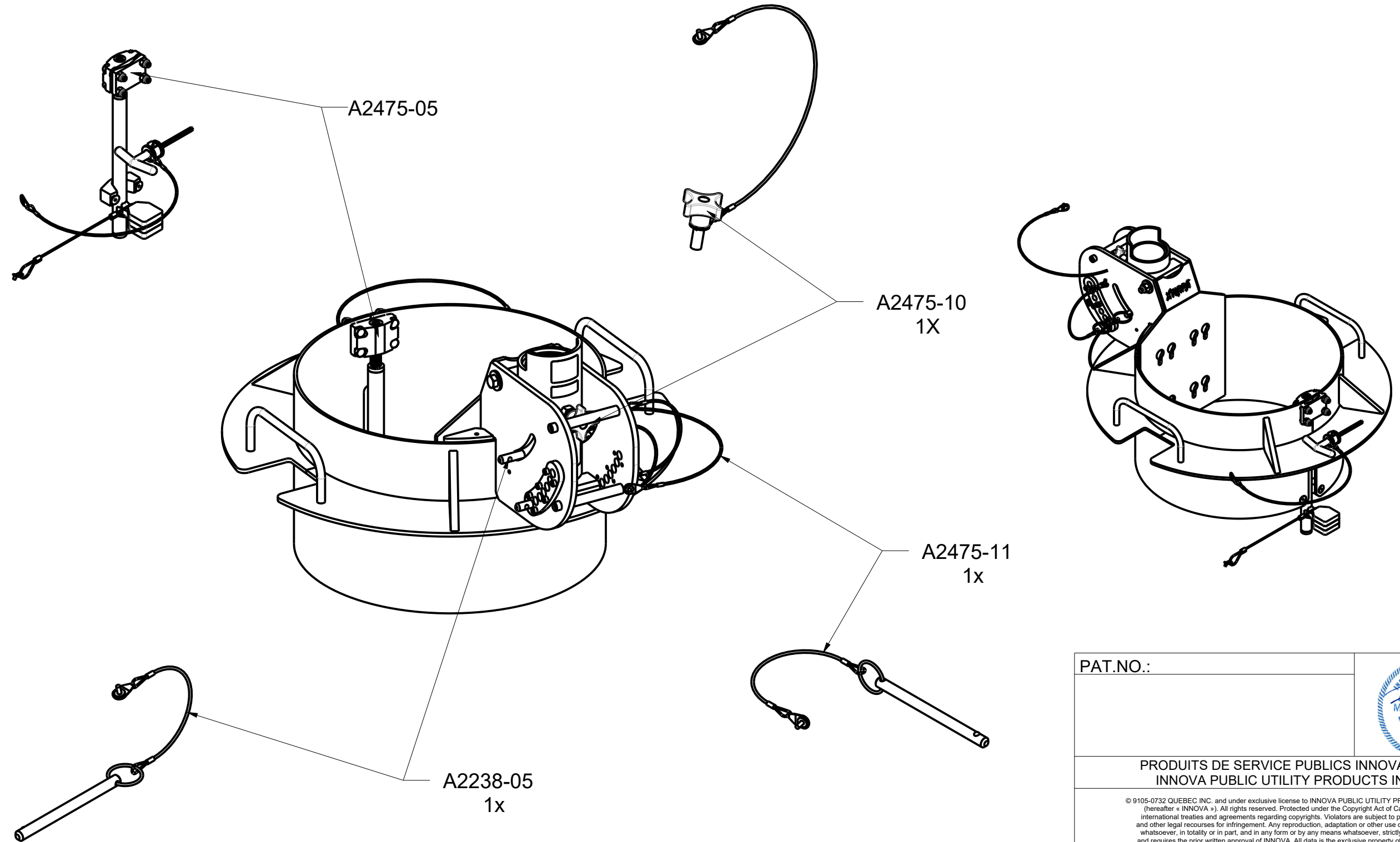

PAT.NO.:

PRODUITS DE SERVICE PUBLICS INNOVA INC.
INNOVA PUBLIC UTILITY PRODUCTS INC.

© 9105-0732 QUEBEC INC. and under exclusive license to INNOVA PUBLIC UTILITY PRODUCTS INC., (hereafter « INNOVA »). All rights reserved. Protected under the Copyright Act of Canada and international treaties and agreements regarding copyrights. Violators are subject to prosecution and other legal recourses for infringement. Any reproduction, adaptation or other use or disclosure whatsoever, in totality or in part, and in any form or by any means whatsoever, strictly forbidden and requires the prior written approval of INNOVA. All data is the exclusive property of 9105-0732 QUEBEC INC. and under exclusive license to INNOVA and cannot be used nor disclosed in any way either without the prior written approval of INNOVA.

WEIGHT:	TITLE:
48 Lb 22 Kg	508mm (20") Manhole collar 0-30 degree

COLOR:	Material:	SHEET(S):	PROJET:	Rev.
Safety yellow	Aluminum	4 / 4	IN-2497	01