

GALVANIZED STEEL

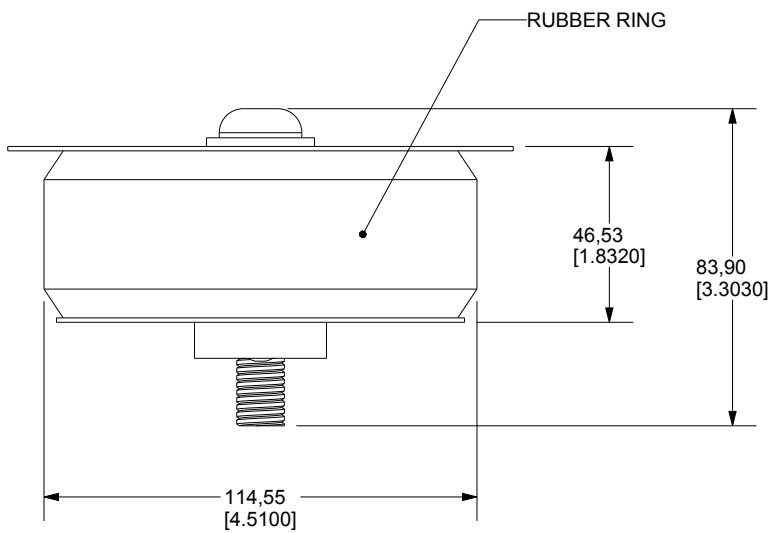
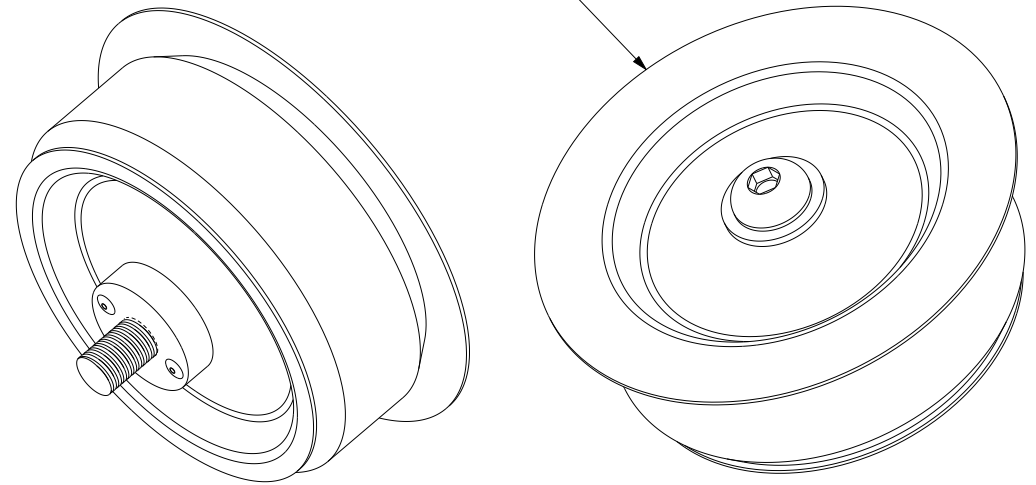

INNOVA PUBLIC UTILITY PRODUCTS INC.

TITLE:
114mm (4.5") ADAPTER CAP

WEIGHT :		DRAWN BY:		
(kg)	(lb)	S. DECHAMPS		
0.5	1.1	DATE: 2025-04-30		
		SCALE: 1:2		
MATERIAL:		SHEET(S):	FORMAT:	No. DRAWING:
STEEL / RUBBER		1 / 2	A	DA2591-01_ANG
				REV.:

© 9105-0732 QUEBEC INC., under exclusive license to PRODUCTS DE SERVICES PUBLICS INNOVA INC., (hereinafter "INNOVA"). All rights reserved. Protected by the Copyright Act in Canada and international treaties and conventions relating to copyright. Violators are subject to criminal prosecution and other legal remedies for infringement. Any reproduction, adaptation or other use or disclosure of any kind, in whole or in part, and in any form or by any means whatsoever either, is strictly prohibited and requires the prior written consent of INNOVA. The data is the exclusive property of 9105-0732 QUEBEC INC., under exclusive license to INNOVA and cannot be used or disclosed in any way without the prior written consent of INNOVA.

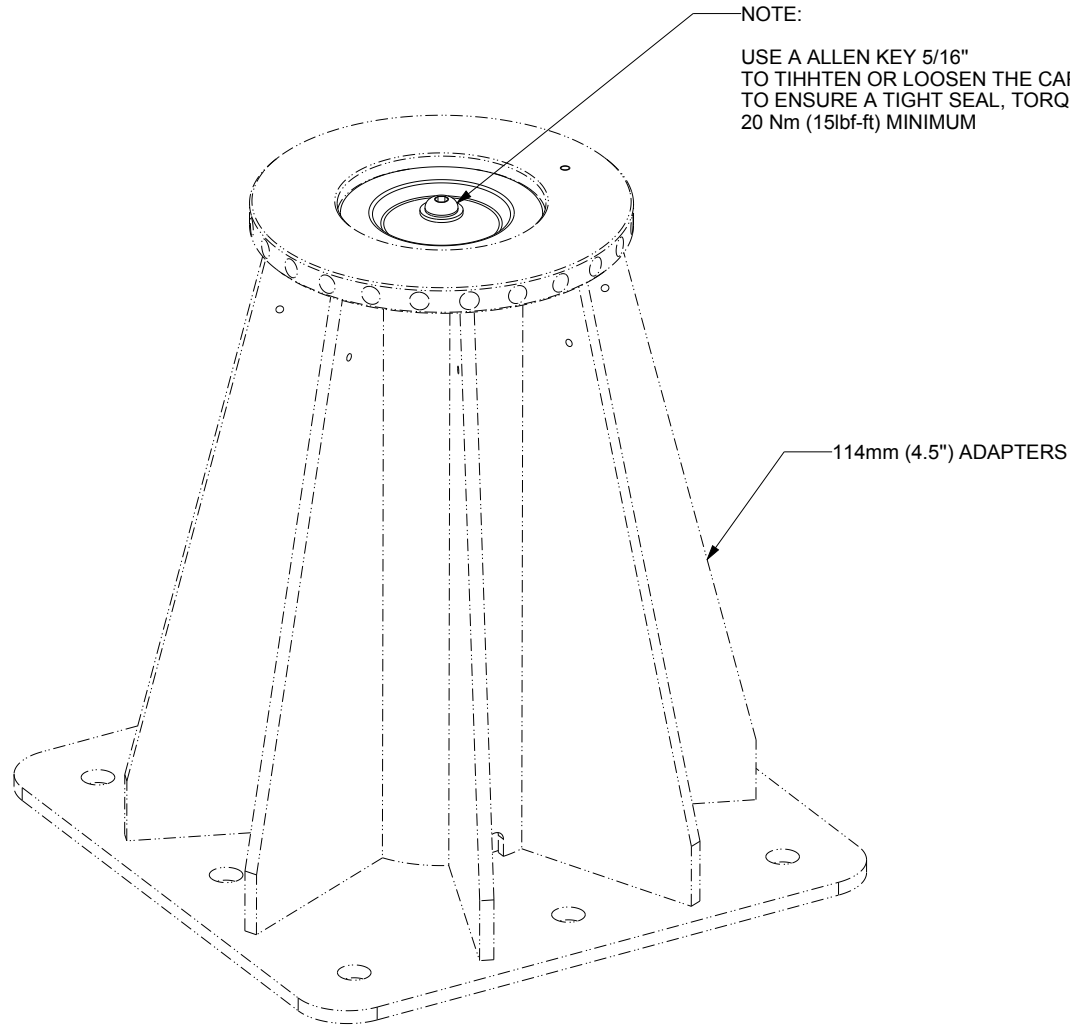

NOTE:
 USE A ALLEN KEY 5/16"
 TO TIHHTEN OR LOOSEN THE CAP.
 TO ENSURE A TIGHT SEAL, TORQUE AT
 20 Nm (15lbf-ft) MINIMUM

114mm (4.5") ADAPTERS

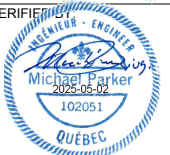
INNOVA PUBLIC UTILITY PRODUCTS INC.				
TITLE:				
114mm (4.5") ADAPTER CAP				
WEIGHT :		DRAWN BY:		VERIFIED BY:
(kg)	(lb)	S. DECHAMPS		
0.5	1.1	DATE:		
		2025-04-30		
		SCALE:		
		33:100		
MATERIAL:		SHEET(S):	FORMAT:	No. DRAWING:
STEEL / RUBBER		2 / 2	A	DA2591-01 ANG
<small>© 9105-0732 QUEBEC INC., under exclusive license to PRODUCTS DE SERVICES PUBLICS INNOVA INC., (hereinafter "INNOVA"). All rights reserved. Protected by the Copyright Act in Canada and international treaties and conventions relating to copyright. Violators are subject to criminal prosecution and other legal remedies for infringement. Any reproduction, adaptation or other use or disclosure of any kind, in whole or in part, and in any form or by any means whatsoever either, is strictly prohibited and requires the prior written consent of INNOVA. The data is the exclusive property of 9105-0732 QUEBEC INC., under exclusive license to INNOVA and cannot be used or disclosed in any way without the prior written consent of INNOVA.</small>				