

Product number: **A5032-15**

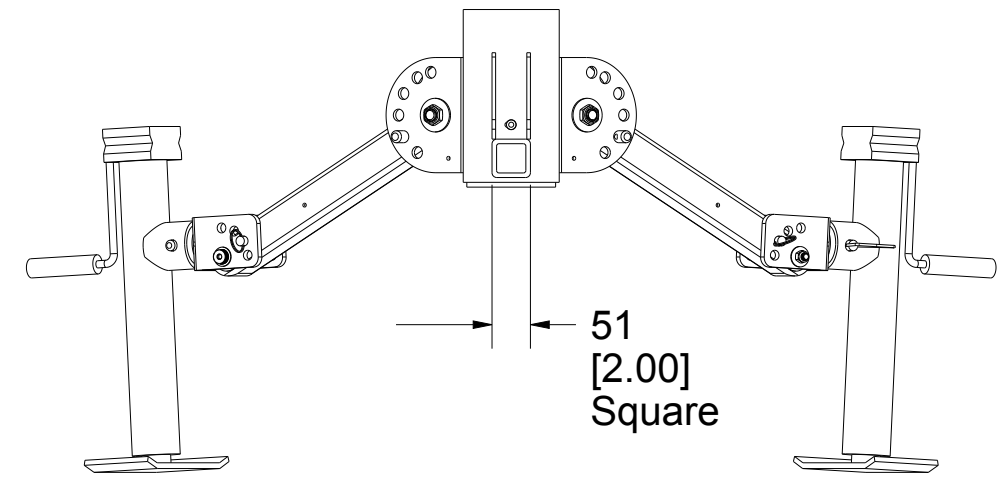

PAT.NO.:				
<p><b>PRODUITS DE SERVICE PUBLICS INNOVA INC.</b>  <b>INNOVA PUBLIC UTILITY PRODUCTS INC.</b></p> <p><small>© 9105-0732 QUEBEC INC. and under exclusive license to INNOVA PUBLIC UTILITY PRODUCTS INC., (hereafter « INNOVA »). All rights reserved. Protected under the Copyright Act of Canada and international treaties and agreements regarding copyrights. Violators are subject to prosecution and other legal recourses for infringement. Any reproduction, adaptation or other use or disclosure whatsoever, in totality or in part, and in any form or by any means whatsoever, strictly forbidden and requires the prior written approval of INNOVA. All data is the exclusive property of 9105-0732 QUEBEC INC. and under exclusive license to INNOVA and cannot be used nor disclosed in any way either without the prior written approval of INNOVA.</small></p>				
WEIGHT:	TITLE:			
59.3 Lb	Extendable Vehicle Hitch System for			
26.9 Kg	Universal Anchor Post			
COLOR:	Material:	SHEET(S):	PROJET:	Rev.
Zinc plated	Steel	1 / 5	A5032-15	04

Product number: **A5032-15**

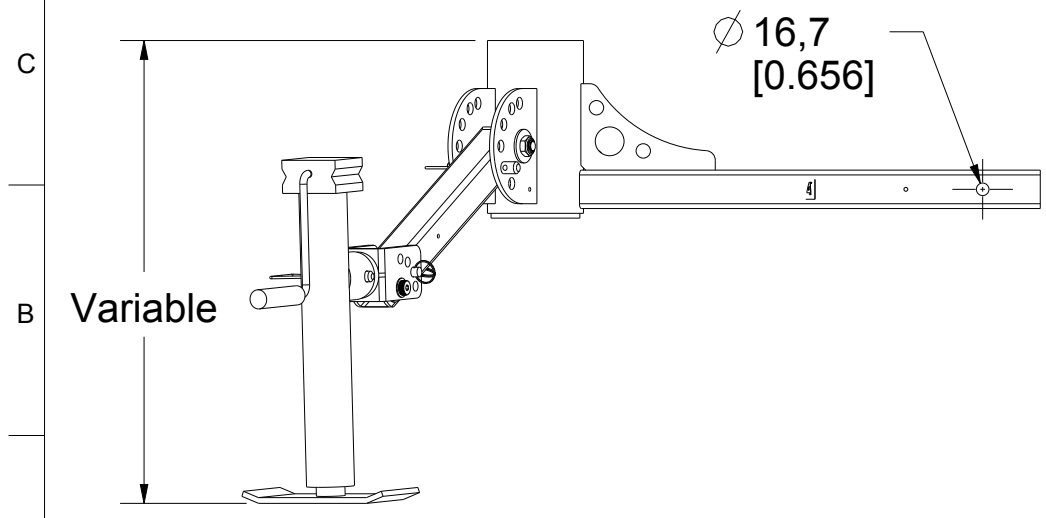
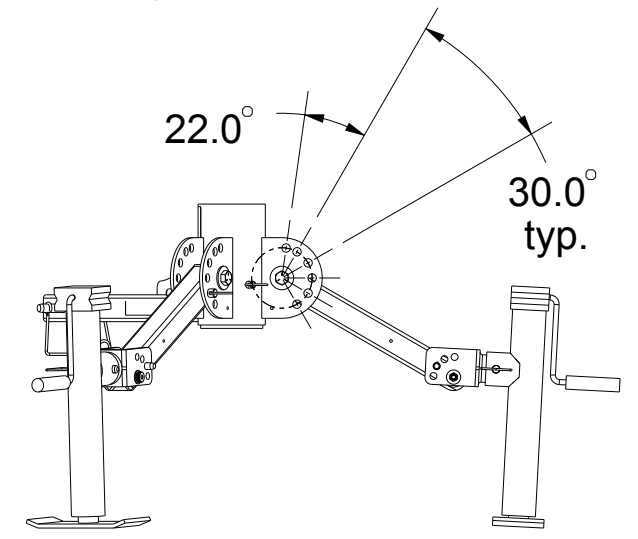
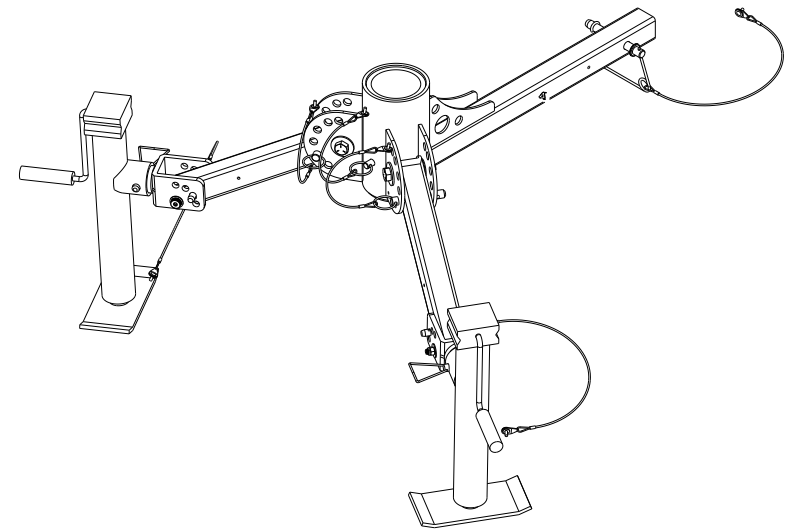
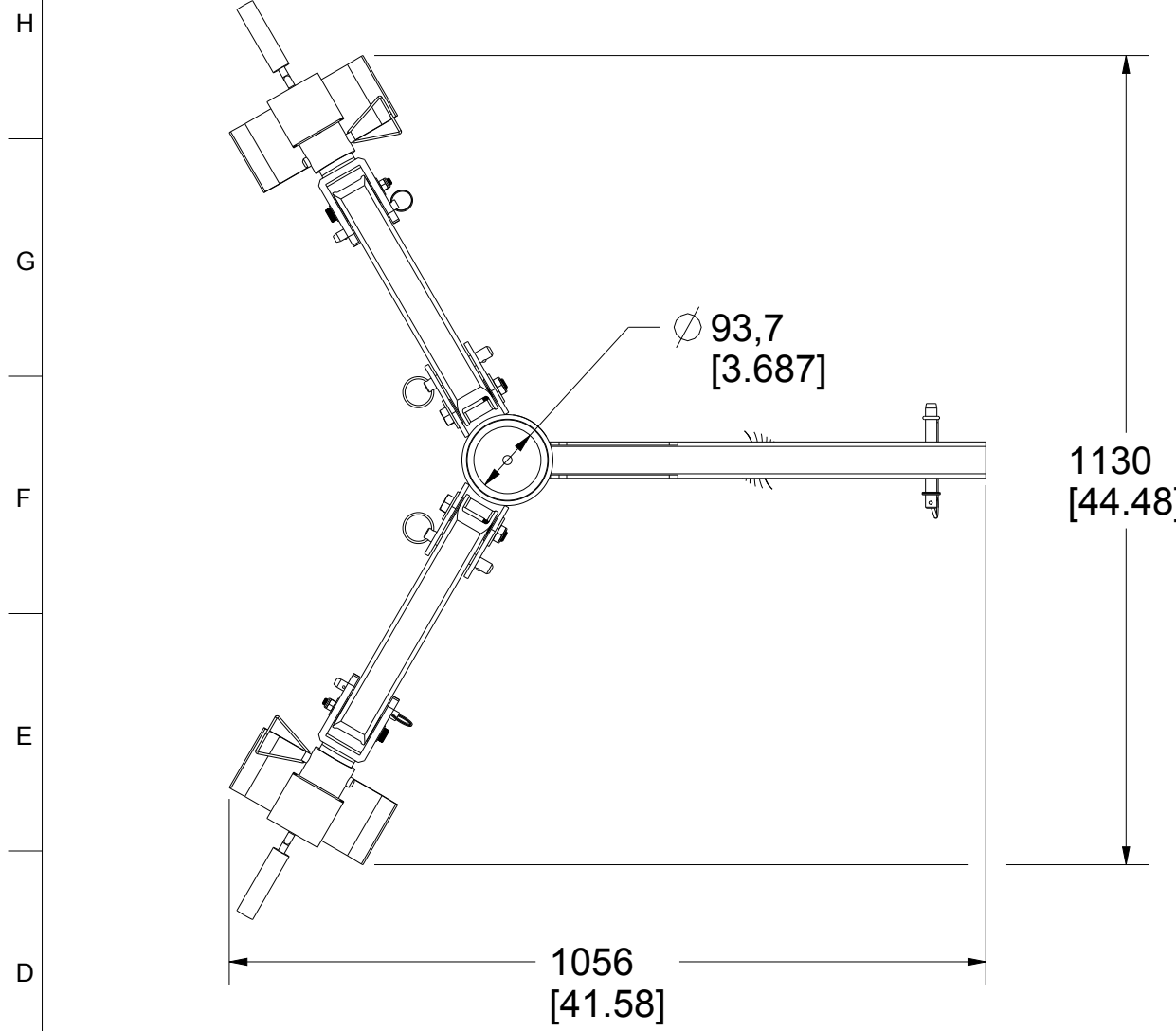
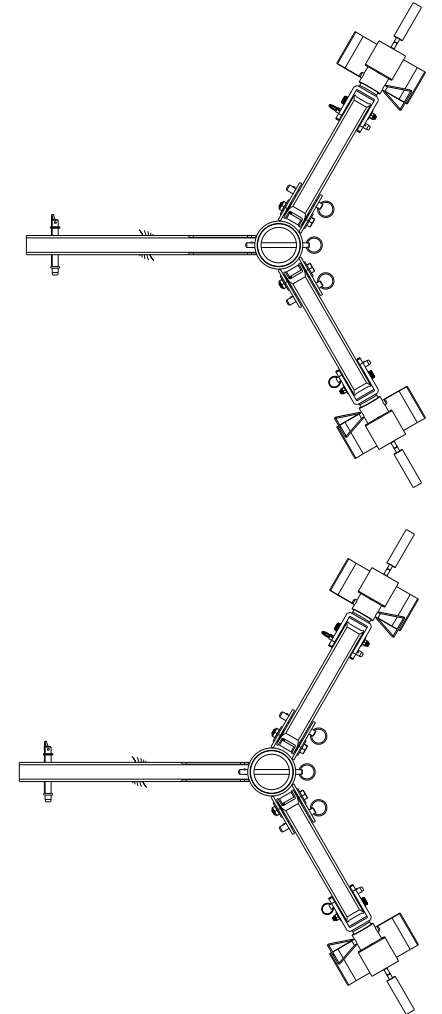
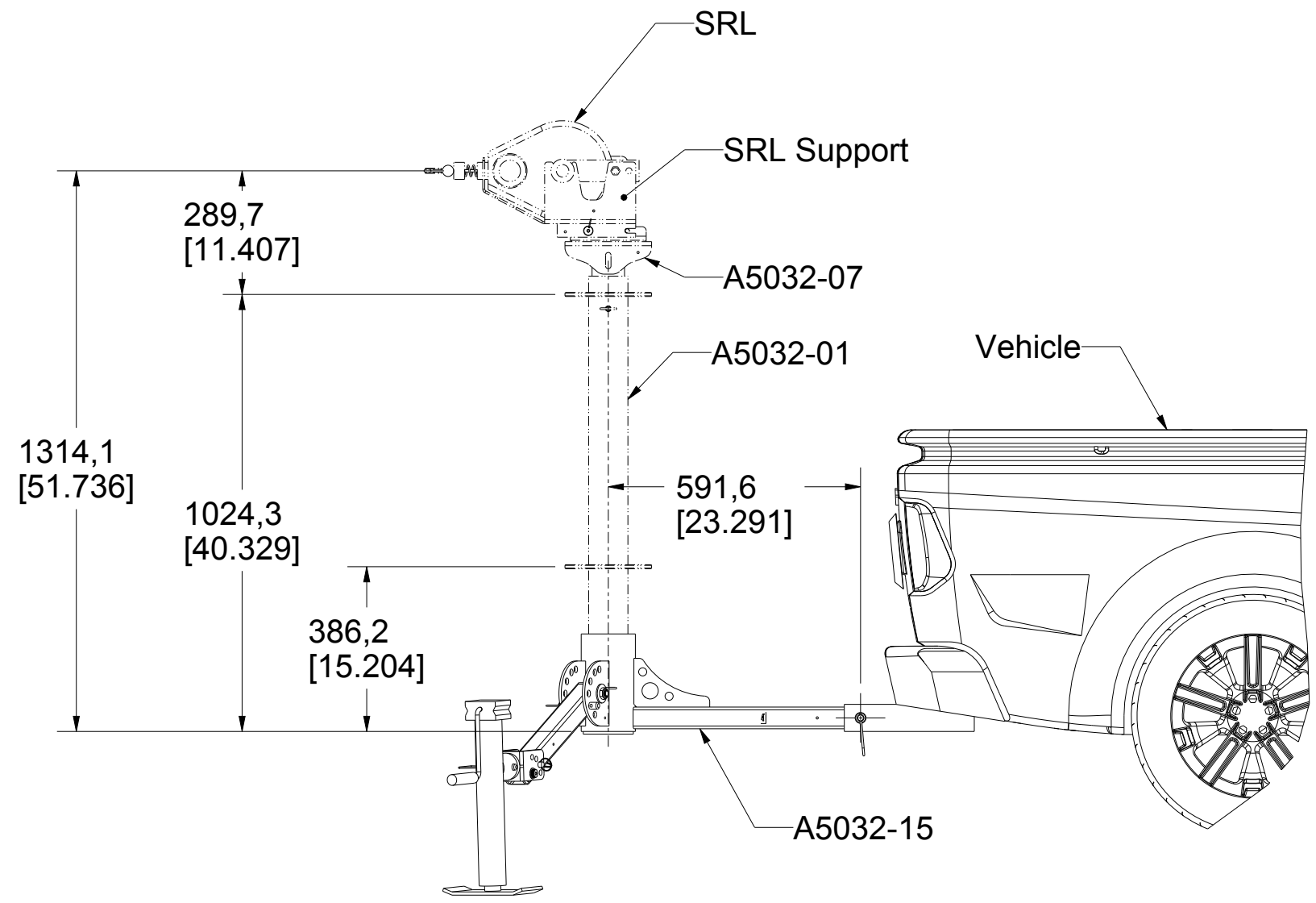

Permissible Working Angle

Permissible Angle of Recuperation

PAT.NO.:				
<b>PRODUITS DE SERVICE PUBLICS INNOVA INC.</b> <b>INNOVA PUBLIC UTILITY PRODUCTS INC.</b>				
© 9105-0732 QUEBEC INC. and under exclusive license to INNOVA PUBLIC UTILITY PRODUCTS INC., (hereafter « INNOVA »). All rights reserved. Protected under the Copyright Act of Canada and international treaties and agreements regarding copyrights. Violators are subject to prosecution and other legal recourses for infringement. Any reproduction, adaptation or other use or disclosure whatsoever, in totality or in part, and in any form or by any means whatsoever, strictly forbidden and requires the prior written approval of INNOVA. All data is the exclusive property of 9105-0732 QUEBEC INC. and under exclusive license to INNOVA and cannot be used nor disclosed in any way either without the prior written approval of INNOVA.				
WEIGHT:	TITLE:			
59.3 Lb	<b>Extendable Vehicle Hitch System for Universal Anchor Post</b>			
26.9 Kg				
COLOR:	Material:	SHEET(S):	PROJET:	Rev.
Zinc plated	Steel	2 / 5	A5032-15	04

Product number: **A5032-15**

Installation with adapter IN-2517 for European trailer ball hitch

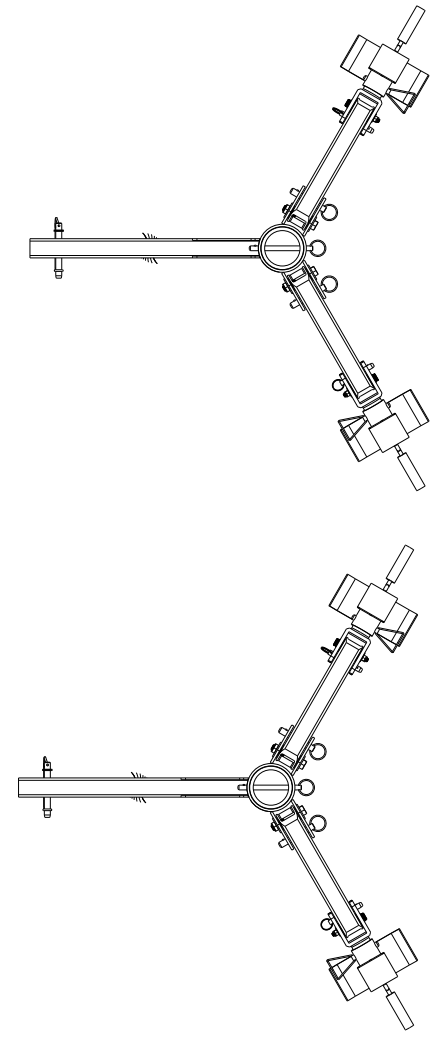
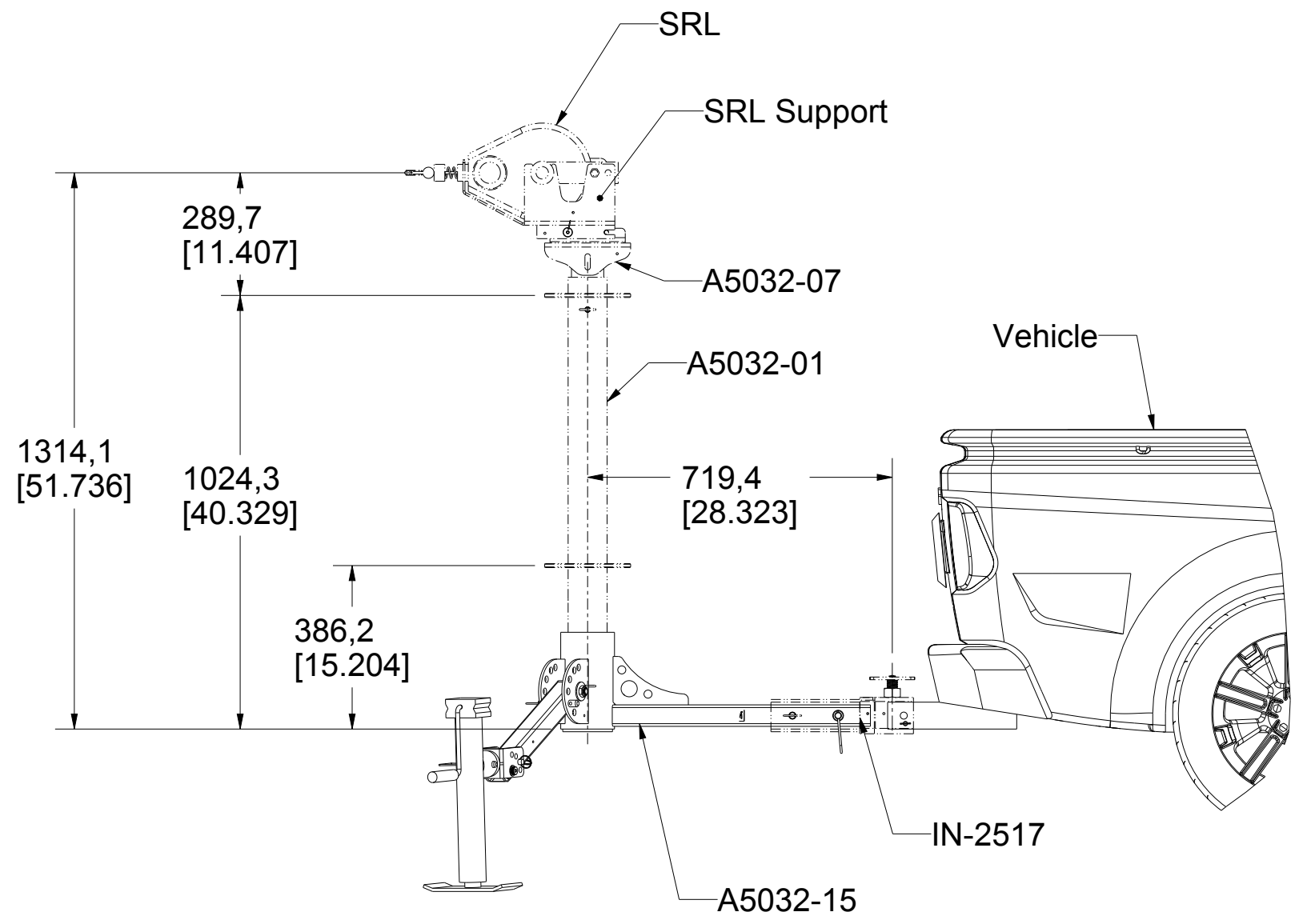

PAT.NO.:				
PRODUITS DE SERVICE PUBLICS INNOVA INC. INNOVA PUBLIC UTILITY PRODUCTS INC.				
<small>© 9105-0732 QUEBEC INC. and under exclusive license to INNOVA PUBLIC UTILITY PRODUCTS INC., (hereafter « INNOVA »). All rights reserved. Protected under the Copyright Act of Canada and international treaties and agreements regarding copyrights. Violators are subject to prosecution and other legal recourses for infringement. Any reproduction, adaptation or other use or disclosure whatsoever, in totality or in part, and in any form or by any means whatsoever, strictly forbidden and requires the prior written approval of INNOVA. All data is the exclusive property of 9105-0732 QUEBEC INC. and under exclusive license to INNOVA and cannot be used nor disclosed in any way either without the prior written approval of INNOVA».</small>				
WEIGHT:	TITLE:			
59.3 Lb	Extendable Vehicle Hitch System for			
26.9 Kg	Universal Anchor Post			
COLOR:	Material:	SHEET(S):	PROJET:	Rev.
Zinc plated	Steel	3 / 5	A5032-15	04

**SPECIFICATIONS**

H This equipment is considered as part of a personal fall arrest system (PFAS).  
 It is only to be used in conjunction with a personal fall arrest system that limits the maximum arrest force (MAF) to 6,0 kN.

G Working Load Limit (WLL) :	164 kg / User	(360 lb) / User
Maximum Working Moment (MWM) :	2,1 kN•m	(18 625 lbf•in)
Horizontal Minimum Breaking Strength :	18,4 kN	(4 136 lbf)
Vertical Minimum Breaking Strength :	18,0 kN	(4 407 lbf)
Maximum Design Moment :	24,2 kN•m	(213 980 lbf•in)

F The axle load must be equal to or greater than 1818 kgf (4 000 lbf).  
 It is recommended to use shims to support the horizontal load of : 12 kN (2 698 lbf).

**STANDARDS**

Name	Classification	Year	Users
E AS / NZS 5532	Freefall arrest	2013	1
ANSI Z359.18	D	2017	1
CSA Z259.15	AD	2017	1
OSHA 1910.140			1
OSHA 1926.502			1
EN 795	A	2012	1
D TS 16415		2013	3

**MATERIAL AND CONSTRUCTION**

Structure :	Steel
Hardware :	Stainless Steel
C Welding certification :	Steel / Stainless Steel : CSA W59.18 / CSA W47.1 and AWS D1.6
Surface finish :	Finish clear zinc plated ASTM B-633-13, Type V, SC 3

**RESTRICTIONS**

B This equipment is to be used only with products approved by Innova Public Utility Products Inc.  
 This equipment must always be operated on a level surface.  
 Ensure that all hardwares and connecting pins are properly installed before use.  
 A In the occurrence of a fall or that the safety of the equipment is in doubt, the equipment must be immediately removed from service and inspected by qualified personnel before reuse.

Product number: **A5032-15**

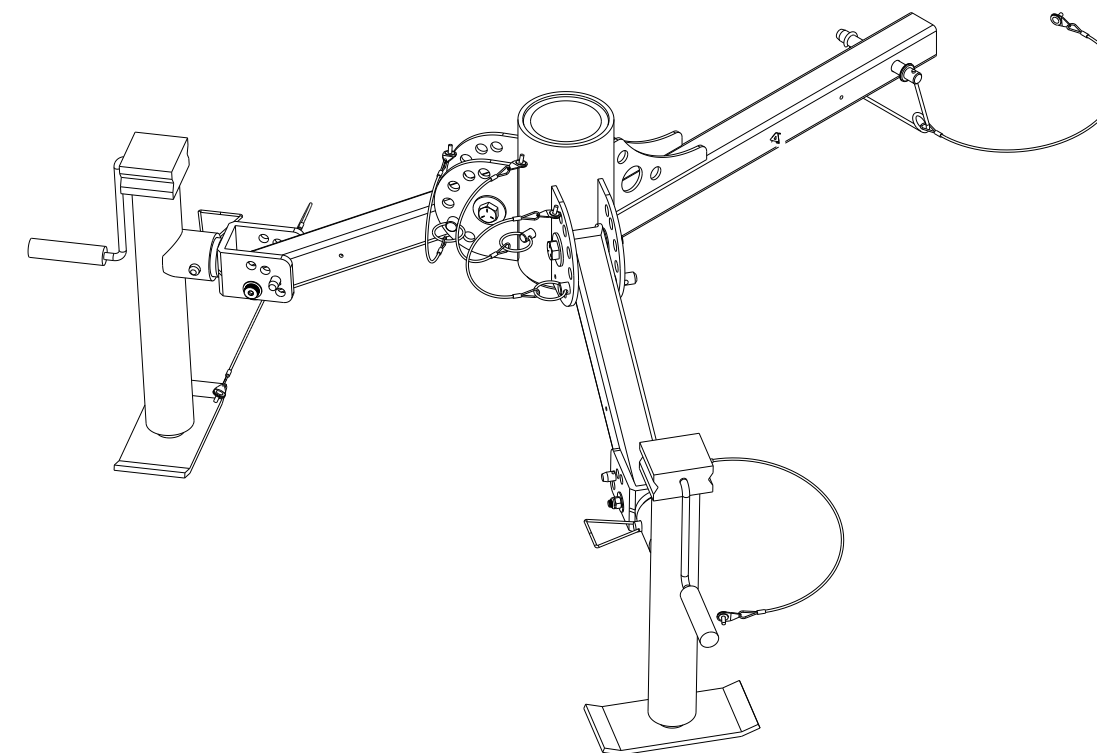

PAT.NO.:				
<b>PRODUITS DE SERVICE PUBLICS INNOVA INC.</b> <b>INNOVA PUBLIC UTILITY PRODUCTS INC.</b>				
© 9105-0732 QUEBEC INC. and under exclusive license to INNOVA PUBLIC UTILITY PRODUCTS INC., (hereafter « INNOVA »). All rights reserved. Protected under the Copyright Act of Canada and international treaties and agreements regarding copyrights. Violators are subject to prosecution and other legal recourses for infringement. Any reproduction, adaptation or other use or disclosure whatsoever, in totality or in part, and in any form or by any means whatsoever, strictly forbidden and requires the prior written approval of INNOVA. All data is the exclusive property of 9105-0732 QUEBEC INC. and under exclusive license to INNOVA and cannot be used nor disclosed in any way either without the prior written approval of INNOVA».				
WEIGHT:	TITLE:			
59.3 Lb	<b>Extendable Vehicle Hitch System for                      Universal Anchor Post</b>			
26.9 Kg				
COLOR:	Material:	SHEET(S):	PROJET:	Rev.
Zinc plated	Steel	4 / 5	A5032-15	04

Product number: **A5032-15**

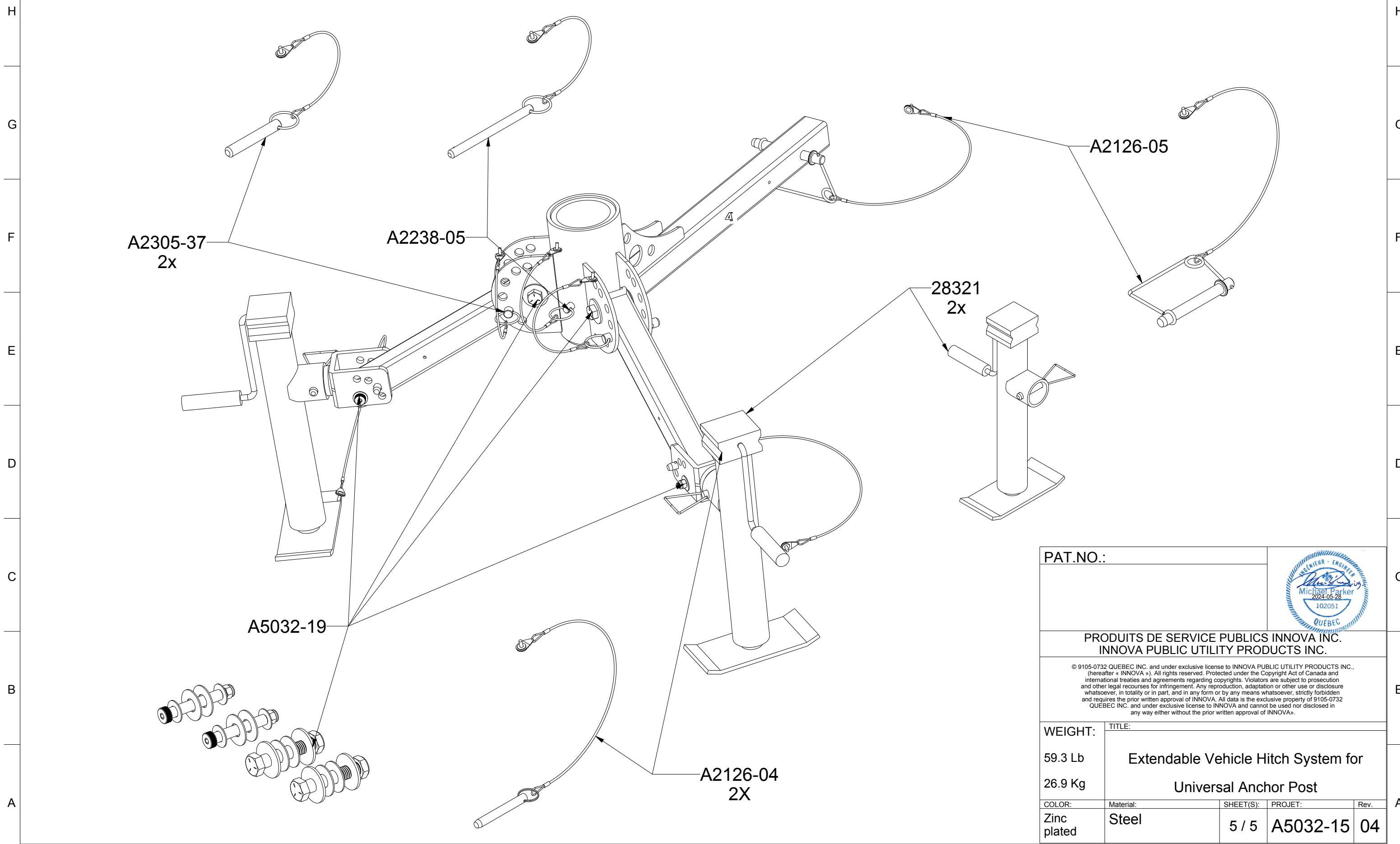

PAT.NO.:				
<b>PRODUITS DE SERVICE PUBLICS INNOVA INC.</b> <b>INNOVA PUBLIC UTILITY PRODUCTS INC.</b>				
© 9105-0732 QUEBEC INC. and under exclusive license to INNOVA PUBLIC UTILITY PRODUCTS INC., (hereafter « INNOVA »). All rights reserved. Protected under the Copyright Act of Canada and international treaties and agreements regarding copyrights. Violators are subject to prosecution and other legal recourses for infringement. Any reproduction, adaptation or other use or disclosure whatsoever, in totality or in part, and in any form or by any means whatsoever, strictly forbidden and requires the prior written approval of INNOVA. All data is the exclusive property of 9105-0732 QUEBEC INC. and under exclusive license to INNOVA and cannot be used nor disclosed in any way either without the prior written approval of INNOVA».				
WEIGHT:	TITLE:			
59.3 Lb	<b>Extendable Vehicle Hitch System for            Universal Anchor Post</b>			
26.9 Kg				
COLOR:	Material:	SHEET(S):	PROJET:	Rev.
Zinc plated	Steel	5 / 5	A5032-15	04