

8 7 6 5 4 3 2 1

Product number: IN-5056

H
G
F
E
D
C
B
A

H
G
F
E
D
C
B
A

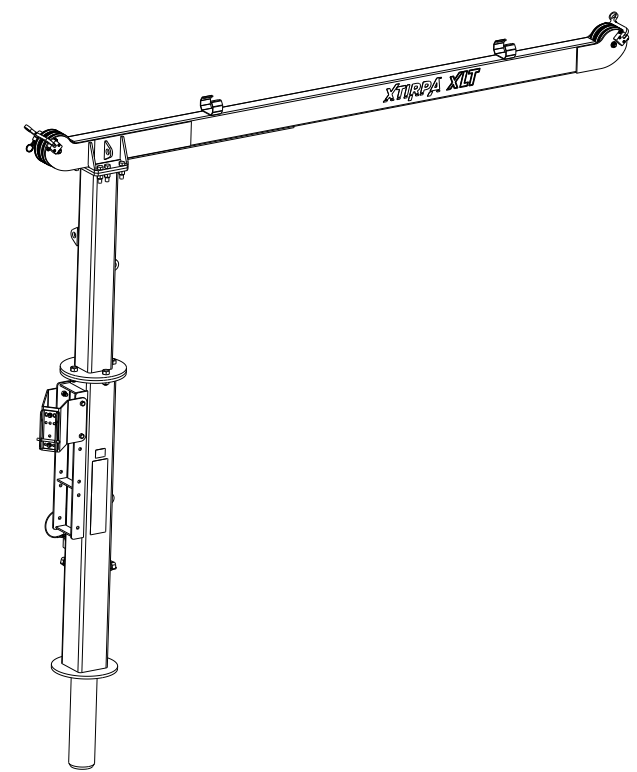
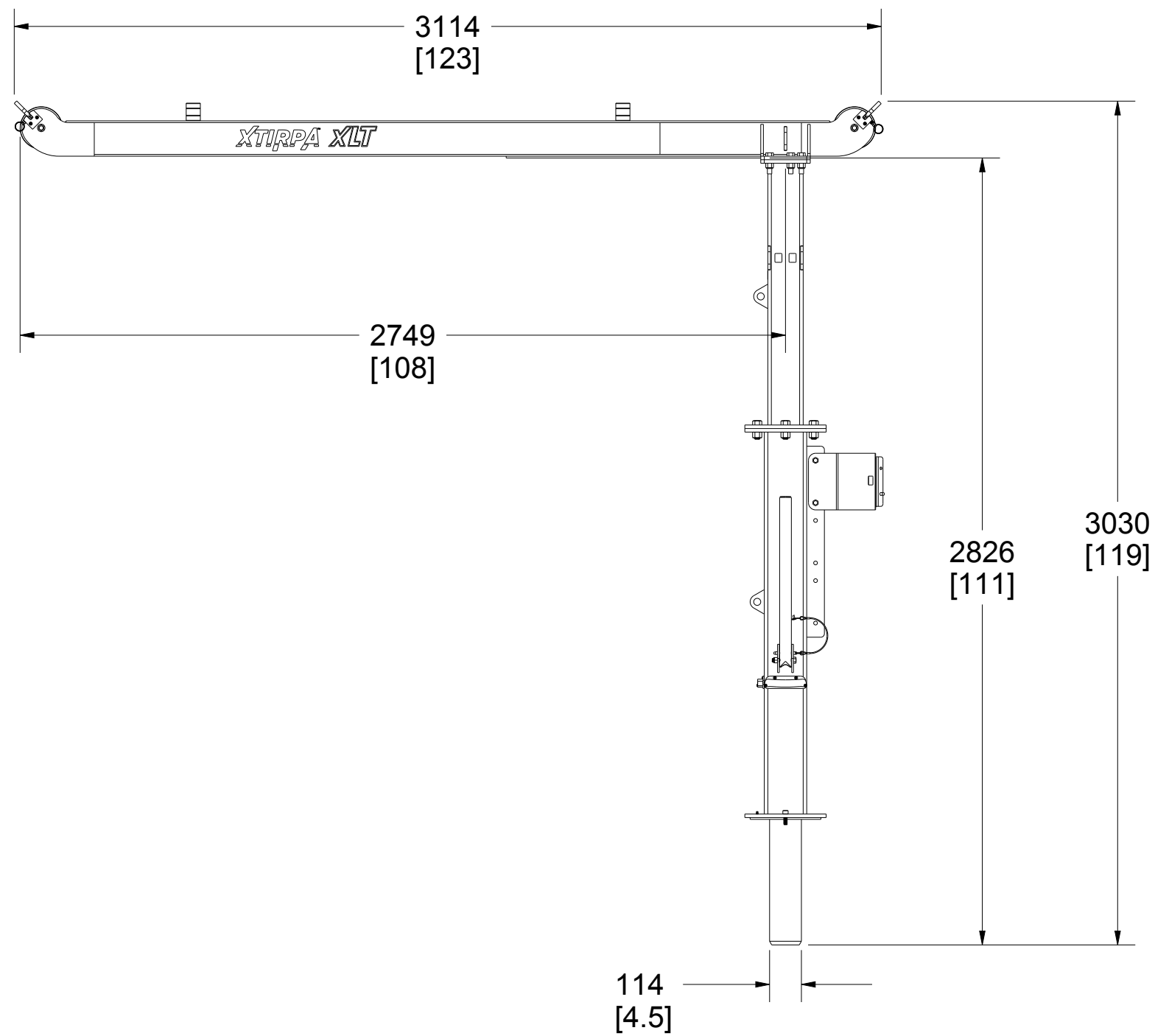

PAT.NO.:				
PRODUITS DE SERVICE PUBLICS INNOVA INC. INNOVA PUBLIC UTILITY PRODUCTS INC.				
© 9105-0732 QUEBEC INC. and under exclusive license to INNOVA PUBLIC UTILITY PRODUCTS INC., (hereafter « INNOVA »). All rights reserved. Protected under the Copyright Act of Canada and international treaties and agreements regarding copyrights. Violators are subject to prosecution and other legal recourses for infringement. Any reproduction, adaptation or other use or disclosure whatsoever, in totality or in part, and in any form or by any means whatsoever, strictly forbidden and requires the prior written approval of INNOVA. All data is the exclusive property of 9105-0732 QUEBEC INC. and under exclusive license to INNOVA and cannot be used nor disclosed in any way either without the prior written approval of INNOVA®.				
WEIGHT:	TITLE:			
359.2 Lb	XLT Mast-DavitArm Fixed Height Reach 2,7m (9ft)			
162.9 Kg				
COLOR:	Material:	SHEET(S):	PROJET:	Rev.
Yellow XTIRPA	Steel	1 / 5	IN-5056	03

8 7 6 5 4 3 2 1

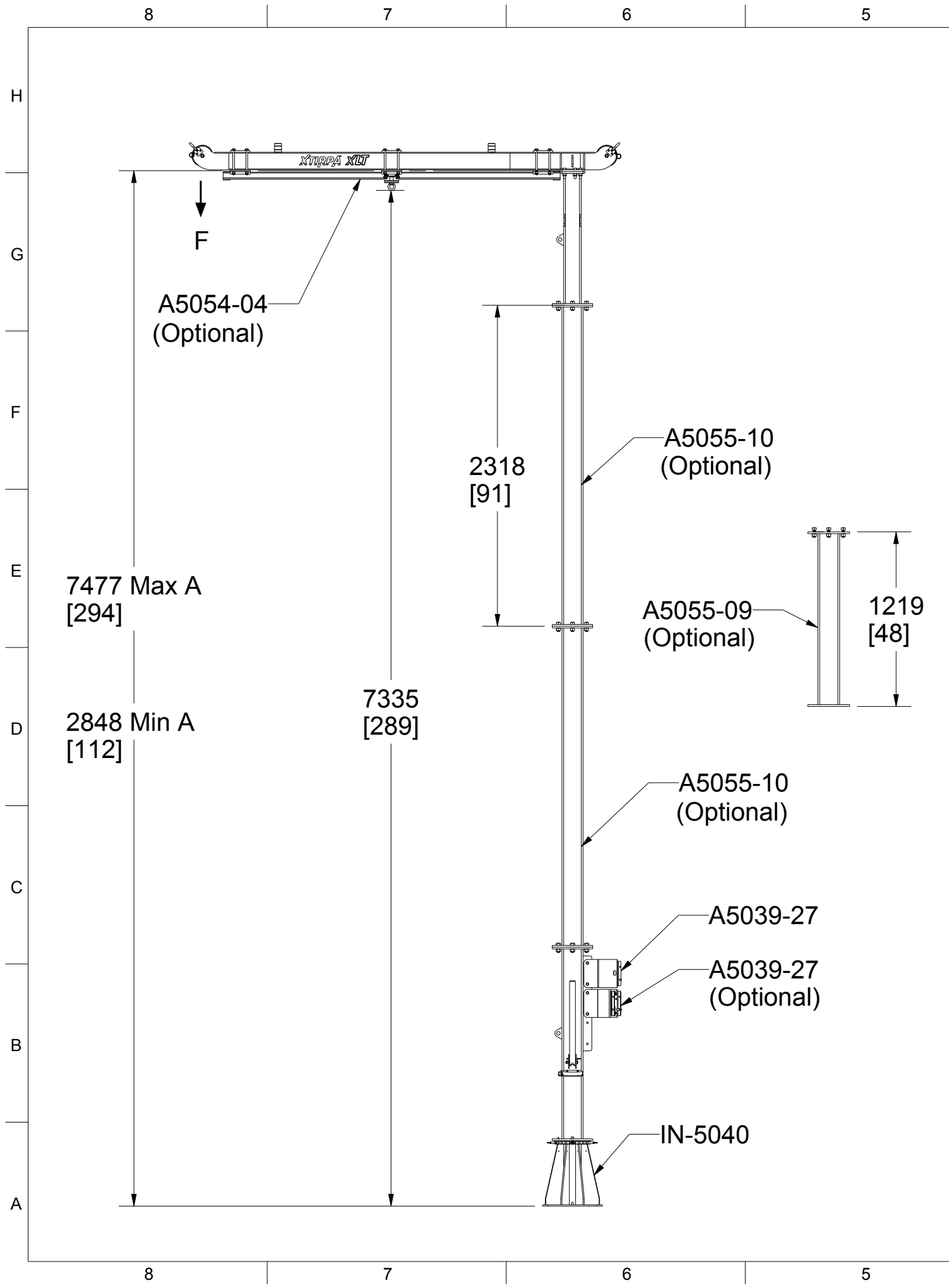

Product number: **IN-5056**

Configuration	1	2	3	4	5	6	7
Davit	IN-5056						
Option		A5055-09	A5055-10	A5055-09	A5055-09	A5055-09	A5055-10
				A5055-09	A5055-10	A5055-09	A5055-10
						A5055-09	
Base	IN-5040						
Height A	2848 [112]	4061 [160]	5159 [203]	5258 [208]	6379 [251]	6499 [256]	7477 [294]

PAT.NO.:				
PRODUITS DE SERVICE PUBLICS INNOVA INC. INNOVA PUBLIC UTILITY PRODUCTS INC.				
© 9105-0732 QUEBEC INC. and under exclusive license to INNOVA PUBLIC UTILITY PRODUCTS INC., (hereafter « INNOVA »). All rights reserved. Protected under the Copyright Act of Canada and international treaties and agreements regarding copyrights. Violators are subject to prosecution and other legal recourses for infringement. Any reproduction, adaptation or other use or disclosure whatsoever, in totality or in part, and in any form or by any means whatsoever, strictly forbidden and requires the prior written approval of INNOVA. All data is the exclusive property of 9105-0732 QUEBEC INC. and under exclusive license to INNOVA and cannot be used nor disclosed in any way either without the prior written approval of INNOVA.				
WEIGHT:	TITLE:			
359.2 Lb	XLT Mast-DavitArm Fixed Height Reach 2,7m (9ft)			
162.9 Kg				
COLOR:	Material:	SHEET(S):	PROJET:	Rev.
Yellow XTIRPA	Steel	2 / 5	IN-5056	03

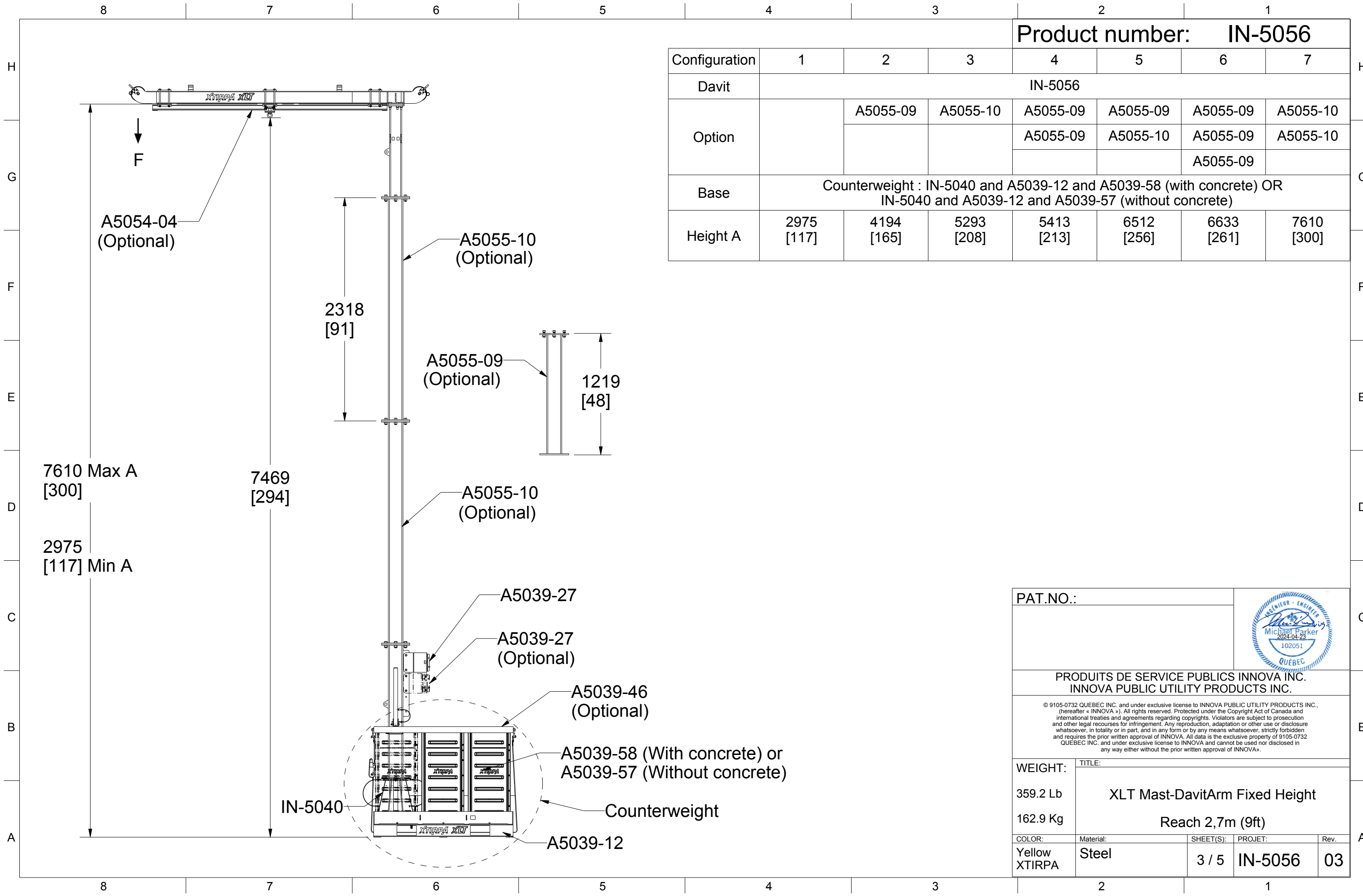

Product number: **IN-5056**

Configuration	1	2	3	4	5	6	7
Davit	IN-5056						
Option		A5055-09	A5055-10	A5055-09	A5055-09	A5055-09	A5055-10
				A5055-09	A5055-10	A5055-09	A5055-10
						A5055-09	
Base	Counterweight : IN-5040 and A5039-12 and A5039-58 (with concrete) OR IN-5040 and A5039-12 and A5039-57 (without concrete)						
Height A	2975 [117]	4194 [165]	5293 [208]	5413 [213]	6512 [256]	6633 [261]	7610 [300]

PAT.NO.:				
PRODUITS DE SERVICE PUBLICS INNOVA INC. INNOVA PUBLIC UTILITY PRODUCTS INC.				
© 9105-0732 QUEBEC INC. and under exclusive license to INNOVA PUBLIC UTILITY PRODUCTS INC., (hereafter « INNOVA »). All rights reserved. Protected under the Copyright Act of Canada and international treaties and agreements regarding copyrights. Violators are subject to prosecution and other legal recourses for infringement. Any reproduction, adaptation or other use or disclosure whatsoever, in totality or in part, and in any form or by any means whatsoever, strictly forbidden and requires the prior written approval of INNOVA. All data is the exclusive property of 9105-0732 QUEBEC INC. and under exclusive license to INNOVA and cannot be used nor disclosed in any way either without the prior written approval of INNOVA.				
WEIGHT:	TITLE:			
359.2 Lb	XLT Mast-DavitArm Fixed Height Reach 2,7m (9ft)			
162.9 Kg				
COLOR:	Material:	SHEET(S):	PROJET:	Rev.
Yellow XTIRPA	Steel	3 / 5	IN-5056	03

SPECIFICATIONS

H This equipment is considered as part of a personal fall arrest system (PFAS).
 It is only to be used in conjunction with a personal fall arrest system that limits the maximum arrest force (MAF) to 6.0 kN.

G Working load limit (WLL) : 164 kg (360 lb)
 Minimum breaking strength for anchorage 1 (F1): 12.0 kN (2698 lbf)
 Minimum breaking strength for anchorage 2 (F2): 12.0 kN (2698 lbf)
 Minimum breaking strength for anchorage 3 (F3): 12.0 kN (2698 lbf)
 Minimum breaking strength for anchorage 4 (F4): 12.0 kN (2698 lbf)

STANDARDS

Name	Classification	Year	Users
AS/NZS 5532	Freefall Arrest	2013	1
ANSI Z359.18	D	2017	1
CSA Z259.15	AD	2017	1
OSHA 1910.140			1
OSHA 1926.502			1
EN 795	A,E	2012	1
TS 16415		2013	2

MATERIAL AND CONSTRUCTION

D Structure : Steel
 Welding procedure : CSA W47,2M / CSA W59.1 & W47.1 & AWS D1.6
 Surface Finishing : Yellow XTIRPA

RESTRICTIONS

B This equipment is to be used only with products approved by Innova Public Utility Products Inc.
 This equipment must always be operated on a level surface.
 Ensure that all hardware and connecting pins are properly installed before use.
 In the occurrence of a fall or the safety of the equipment is in doubt, the equipment must be immediately removed from service and inspected by qualified personnel before reuse.

Product number: **IN-5056**

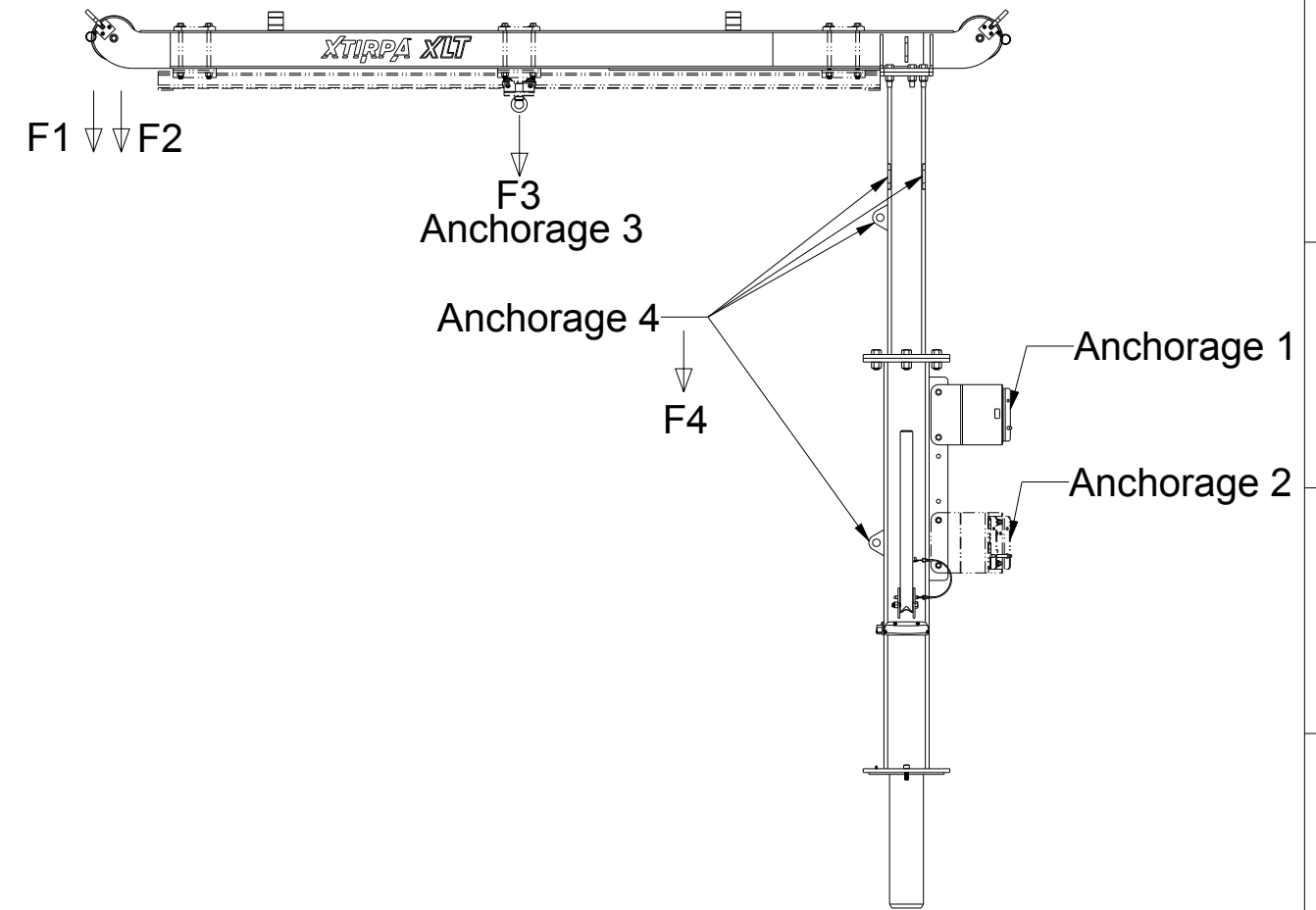

PAT.NO.:				
PRODUITS DE SERVICE PUBLICS INNOVA INC. INNOVA PUBLIC UTILITY PRODUCTS INC.				
<small>© 9105-0732 QUEBEC INC. and under exclusive license to INNOVA PUBLIC UTILITY PRODUCTS INC., (hereafter « INNOVA »). All rights reserved. Protected under the Copyright Act of Canada and international treaties and agreements regarding copyrights. Violators are subject to prosecution and other legal recourses for infringement. Any reproduction, adaptation or other use or disclosure whatsoever, in totality or in part, and in any form or by any means whatsoever, strictly forbidden and requires the prior written approval of INNOVA. All data is the exclusive property of 9105-0732 QUEBEC INC. and under exclusive license to INNOVA and cannot be used nor disclosed in any way either without the prior written approval of INNOVA.</small>				
WEIGHT:	TITLE:			
359.2 Lb	XLT Mast-DavitArm Fixed Height			
162.9 Kg	Reach 2,7m (9ft)			
COLOR:	Material:	SHEET(S):	PROJET:	Rev.
Yellow XTIRPA	Steel	4 / 5	IN-5056	03

Product number: **IN-5056**

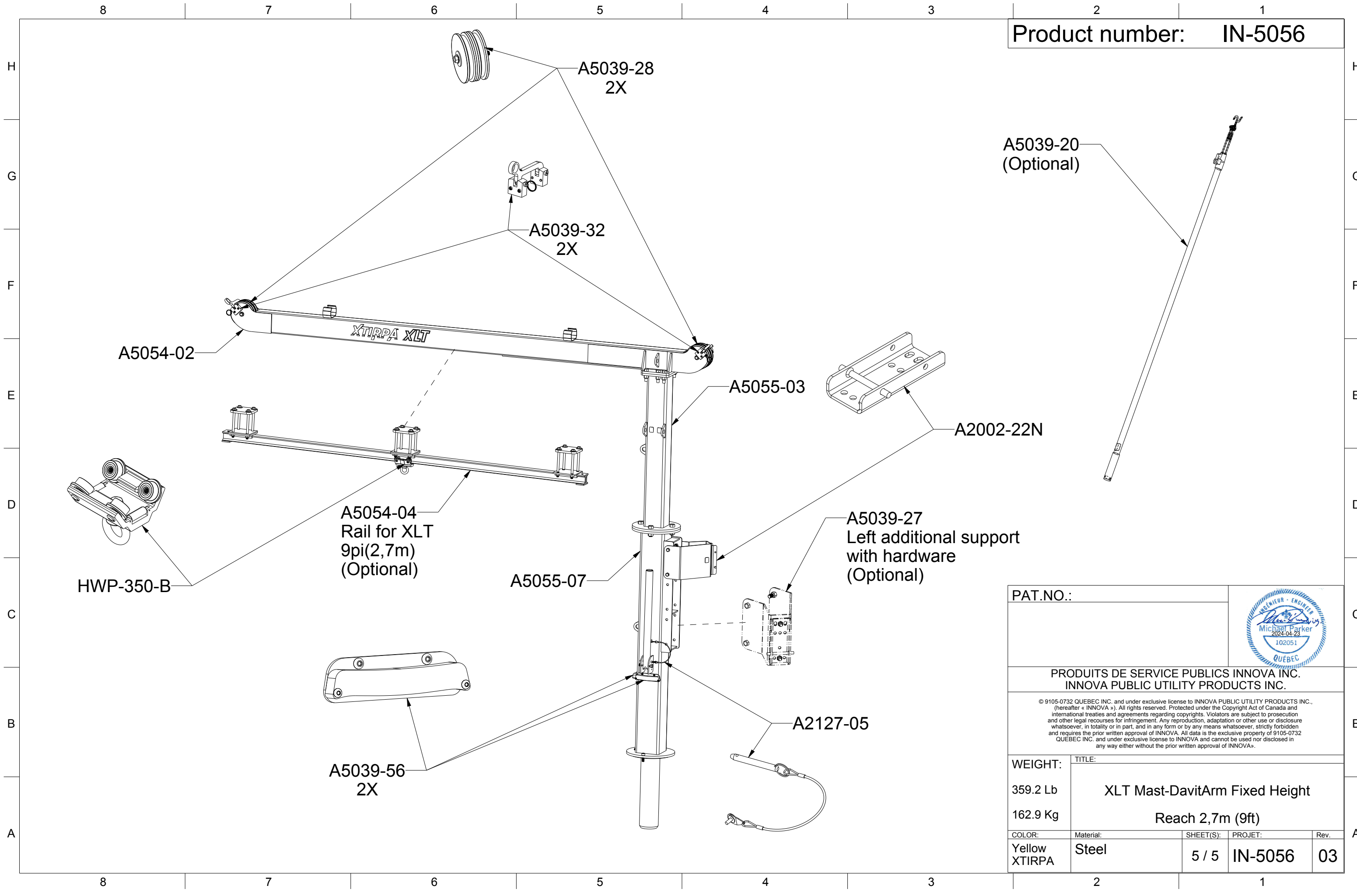

PAT.NO.:				
PRODUITS DE SERVICE PUBLICS INNOVA INC. INNOVA PUBLIC UTILITY PRODUCTS INC.				
<small>© 9105-0732 QUEBEC INC. and under exclusive license to INNOVA PUBLIC UTILITY PRODUCTS INC., (hereafter « INNOVA »). All rights reserved. Protected under the Copyright Act of Canada and international treaties and agreements regarding copyrights. Violators are subject to prosecution and other legal recourses for infringement. Any reproduction, adaptation or other use or disclosure whatsoever, in totality or in part, and in any form or by any means whatsoever, strictly forbidden and requires the prior written approval of INNOVA. All data is the exclusive property of 9105-0732 QUEBEC INC. and under exclusive license to INNOVA and cannot be used nor disclosed in any way either without the prior written approval of INNOVA.</small>				
WEIGHT:	TITLE:			
359.2 Lb	XLT Mast-DavitArm Fixed Height Reach 2,7m (9ft)			
162.9 Kg				
COLOR:	Material:	SHEET(S):	PROJET:	Rev.
Yellow XTIRPA	Steel	5 / 5	IN-5056	03